

- The valve prevents runaway in the event of a negative load
- Smooth and continuous motion by maintaining a constant back pressure
- Load-holding with minimal leakage
- When installed into the actuator the valve can be used as a hose burst valve
- The valve should be mounted as close as possible to the actuator

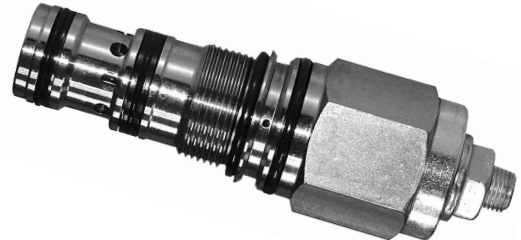
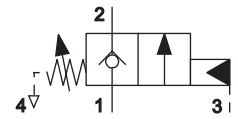

Functional Description

The valve consists of a seat relief valve fitted with an auxiliary control and by-pass single-way valve serving for reverse direction of flow. The liquid is flowing through the single-way valve from the channel (2) to the channel (1) with a small pressure drop. In the opposite direction the single-way valve on the rear side of which a gate valve seat is fitted is pressed through the action of a spring and the load pressure against the spring-loaded valve gate valve. In this way the valve is nearly closed hermetically. For ensuring the function of holding the load the spring force should be set up to a value by 30 % higher when compared to an expected pressure exerted by the load. If a load pressure caused by the action of the force on the consumer or in consequence of the liquid thermal dilatation exceeds a set up value of the spring force the gate valve is pressed out of the seat and the overpressure in that case is relieved from channel (1) to channel (2).

If the load has to be moved in opposite direction from the other connection of the consumer being in that case under pressure it is possible to ensure it with the help of so called auxiliary control from the channel (3) by introducing already certain control pressure.

The necessary control pressure for opening the valve corresponds to the difference between the set up pressure and load pressure. In the formula as mentioned above it is necessary to take into consideration that in differential cylinders it is necessary to take into consideration the relation of surfaces of the cylinder piston in the direction of movement.

As soon as the control pressure attains a necessary value the gate valve is moved out from the seat and then the way from the channel (1) to the channel (2) is released.

If now the load tries to accelerate and be fast as for the oil supply the supply pressure decreases, therefore, also the control pressure in the channel (3) is reduced. The spring force tries to shut off the valve again, therefore, in consequence of which the supply flow to the consumer is reduced and the inlet pressure increases again. In this way it is ensured a constant inlet pressure by means of which it would be possible to control the movement of the load.

As for appropriate basic surface finish the external parts are zinc coated.

The control pressure is calculated in the following way:
Control pressure = set up pressure – load pressure.

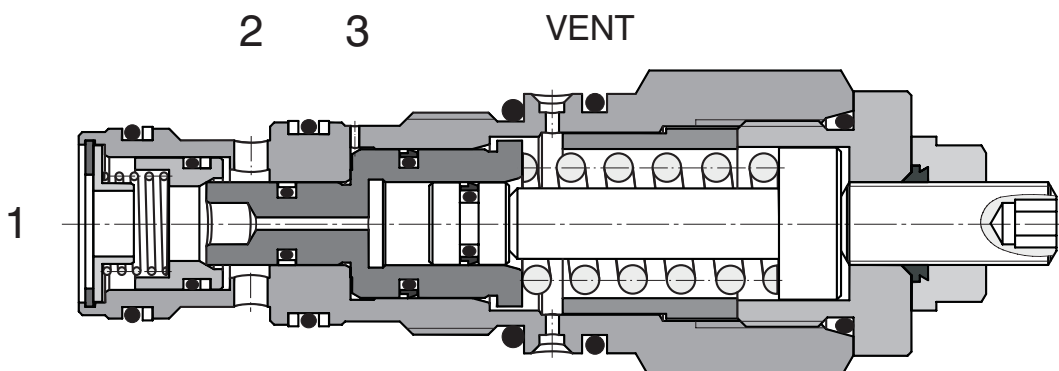

Ordering Code

SOZD5A-R4/I

Overcentre valve
Zero Differential

No designation

Seals
NBR

Pressure range
5 - 20 bar

2

Factory setting 10 bar for Q=4.8 L/min

Technical Data

Cavity		M27 x 1.5
Maximum flow	L/min	90
Max. pressure	bar	350
Max. input pressure	bar	5 - 20
Pressure drops	bar	see $\Delta p - Q$ characteristics
Hydraulic fluid		Hydraulic oil (HM, HV) according to DIN 51524
Fluid temperature range	°C	-20 ... +90
Viscosity	mm ² /s	20 ... 400
Maximum degree of fluid contamination		according to ISO 4406 (1999), Class 21/18/15
Weight	kg	0,29
Maximum valve tightening torque in valve body or in control block	Nm	60 ⁺²
Mounting position		any

$\Delta p - Q$ Characteristics

Measured at $v = 40 \text{ mm}^2/\text{s}$

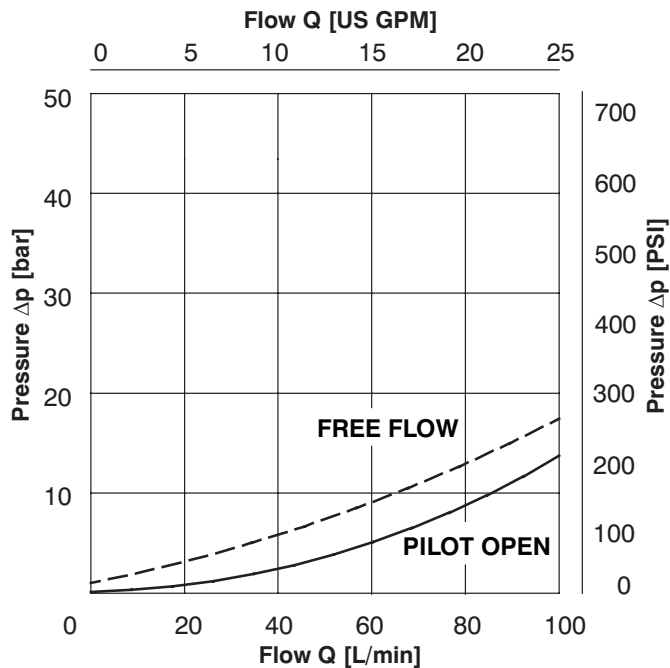

Dimensions

Measurements in millimeters

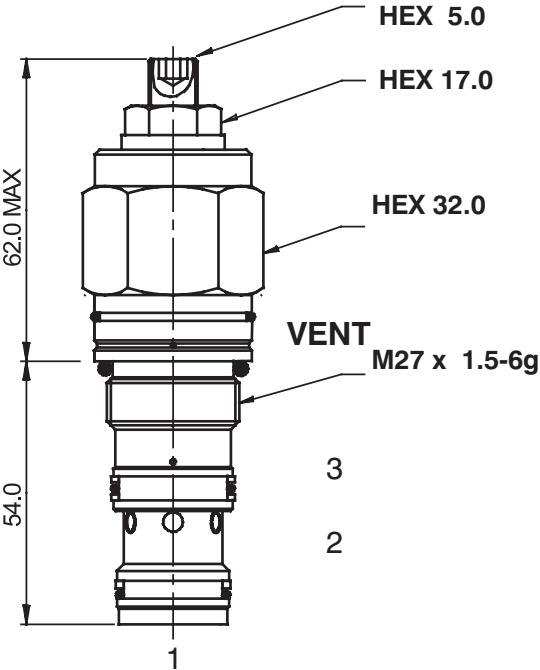

Cavity

Measurements in millimeters

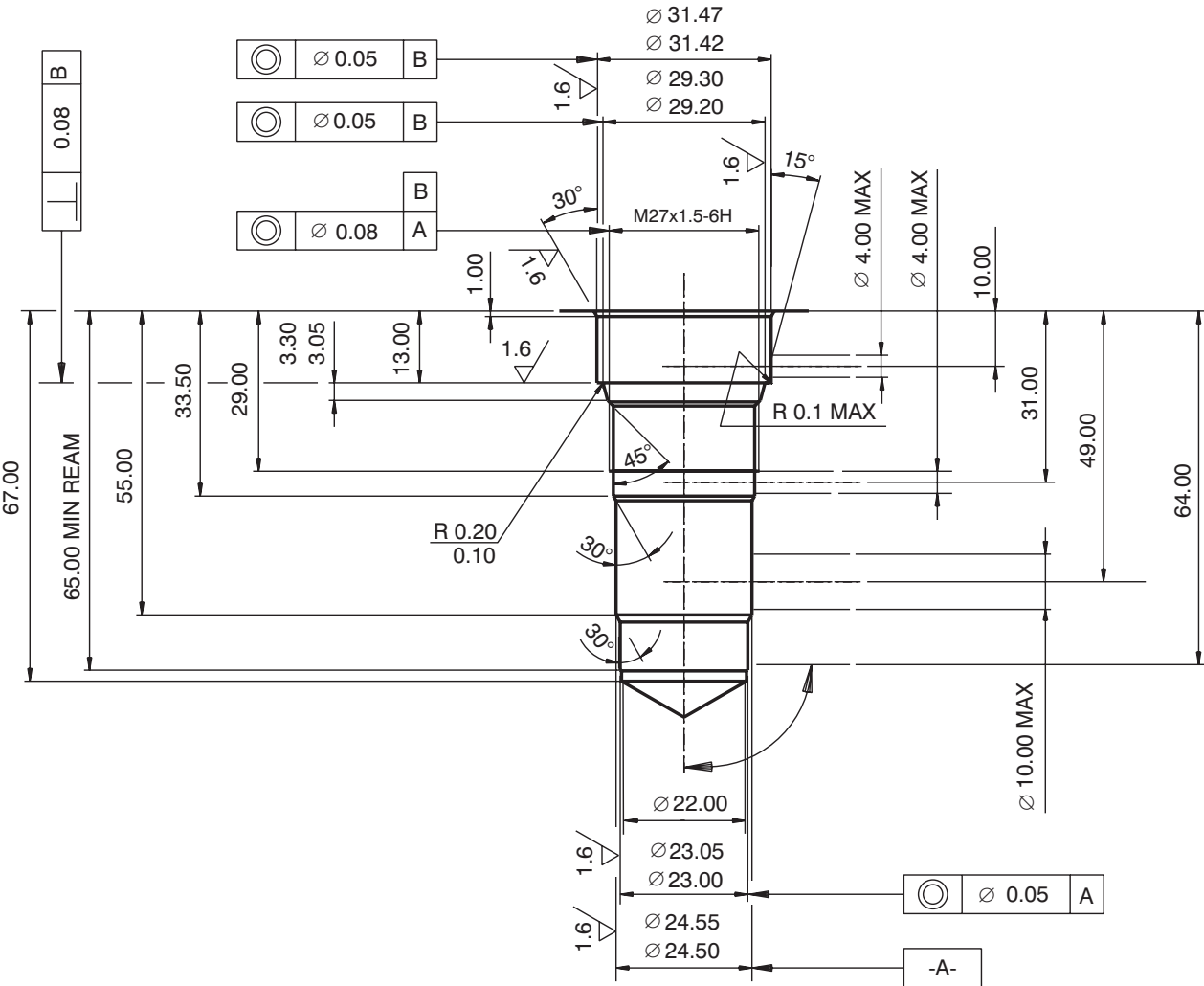

Spare Parts

Seal kits on request.

Caution!

- The packing foil is recyclable.
- The technical information regarding the product presented in this catalogue is for descriptive purposes only. It should not be construed in any case as a guaranteed representation of the product properties in the sense of the law.

ARGO-HYTOS s.r.o. CZ - 543 15 Vrchlabí
Tel.: +420-499-403111, Fax: +420-499-403421
E-mail: sales.cz@argo-hytos.com
www.argo-hytos.com