

- Compact design with integrated electronics
- High reliability
- Simple replacement of the exciting coils including electronics without opening the hydraulic circuits
- Continuous flow control in both directions
- Installation dimensions to DIN 24 340 / ISO 4401 / CETOP RP121-H

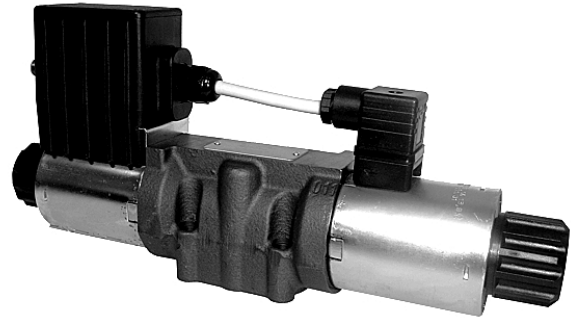
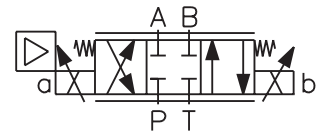

## Functional Description

The proportional directional valve consists of a cast-iron housing, a special control spool, two centering springs with supporting washers and one or two proportional solenoids. A control box, which comprises one or two electronic control cards, depending on the number of the controlled solenoids, can be mounted onto either solenoid. With the model with two solenoids, the solenoid mounted apposite the control box is connected with the box by means of a EN connector, a two-cored cable and a bushing. The connection of the control box with the supply source and with the control signal is realized by means of a 4-pin connector, type M12 x 1. The solenoid coils, including the control box, can be turned in the range of  $\pm 90^\circ$ . The electric control unit supplies the solenoid with current, which varies with the control signal. The solenoid shifts the control spool to the required position, proportional to the control current.

The electronic control unit provides the following adjustment possibilities: Offset, Gain, rise and drop-out time of the ramp generator, frequency (2 frequencies) and amplitude of the dither signal generator. The correct function of the control unit is signaled by LED-diodes. Stabilized voltage +10V (+5V for 12V voltage) is also available for the user. By the use of this voltage, a voltage control signal can be made by means of a potentiometer  $\geq 1 \text{ k}\Omega$ .

The electronic control card enables voltage or current control to be used, according to the positions of the switches SW1 to SW3 (see table on page 6).

The basic surface treatment of the valve housing is phosphate coated, the operating solenoids are zinc coated.

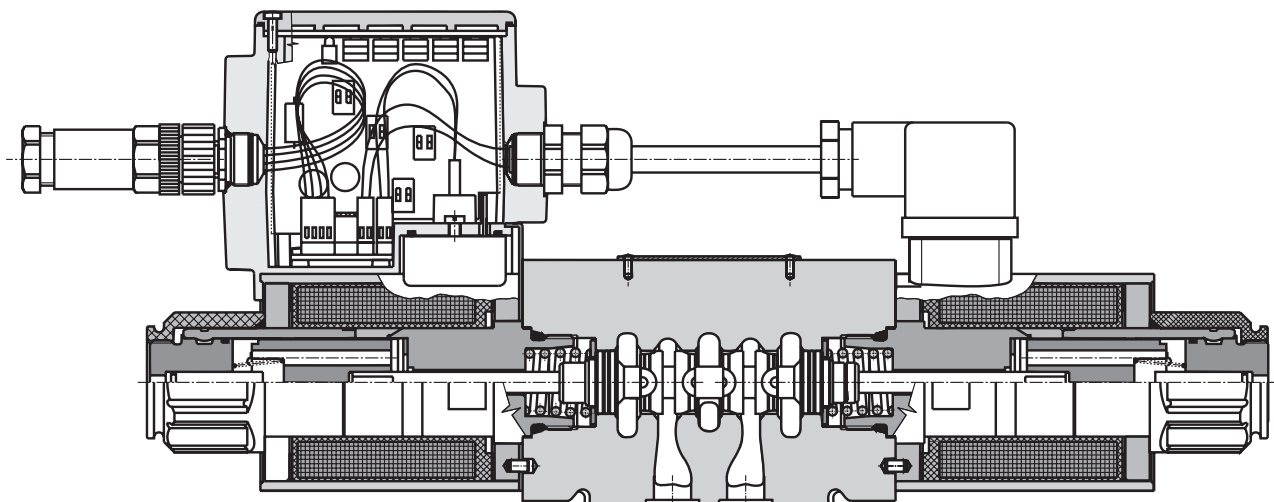

# Ordering Code

**PRM6-10**  /  -

**Proportional Directional Control Valve**

**Seals**

without designation  
**V**

NBR  
FPM (Viton)

**Nominal size**

**10 (D 05)**

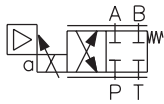

**2Z51**

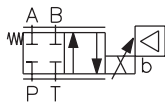

**2Z11**

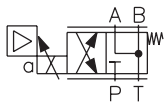

**2Y51**

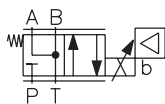

**2Y11**

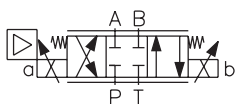

**3Z11**

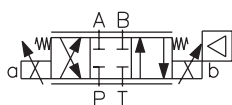

**3Z11B**

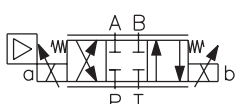

$$\frac{q_A}{q_B} = \frac{1}{2}^*$$

**3Z12**

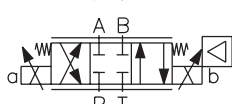

$$\frac{q_A}{q_B} = \frac{1}{2}^*$$

**3Z12B**

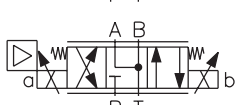

**3Y11**

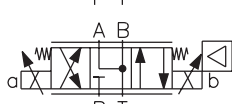

**3Y11B**

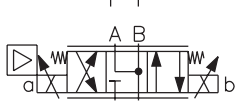

$$\frac{q_A}{q_B} = \frac{1}{2}^*$$

**3Y12**

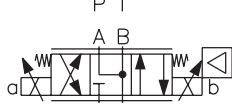

$$\frac{q_A}{q_B} = \frac{1}{2}^*$$

**3Y12B**

**Electronics**

without designation without electronics

**EK**

connection by connector  
M12 x 1 (4-pin connector)  
(supplied with counterpart)

**Nominal supply voltage**

**12**  
**24**

12 V DC  
24 V DC

**Nominal flow rate at Δp = 10 bar (145 PSI)**

**30**  
**60**

30 L/min (7.93 GPM)  
60 L/min (15.85 GPM)

\* Model for cylinders with asymmetric piston rod, piston area ratio 1:2

### Technical Data

Valve size	mm (US)	10 (D 05)
Maximum operating pressure at ports P, A, B	bar (PSI)	320 (4600)
Maximum operating pressure at port T	bar (PSI)	210 (3046)
Hydraulic fluid	Hydraulic oils of power classes (HL, HLP) to DIN 51524	
Fluid temperature range NBR / Viton	°C (°F)	-30 ... +80 (-22 ... +176) / -20 ... +80 (-4 ... +176)
Ambient temperature, max.	°C (°F)	+50 (+122)
Viscosity range	mm <sup>2</sup> /s (SUS)	20 ... 400 (98 ... 1840)
Maximum degree of fluid contamination	Class 21/18/15 to ISO 4406 (1999).	
Nominal flow rate Q <sub>n</sub> at Δp = 145 PSI (10 bar) v = 32 mm <sup>2</sup> ·s <sup>-1</sup> (v = 156 SUS)	L/min (GPM)	30 (7.93) / 60 (15.85)
Hysteresis	%	≤ 6
Weight PRM2-102 PRM2-103	kg (lbs)	4.3 (9.48) 5.8 (12.78)
Mounting position	any, preferably horizontal	
Enclosure type to EN 60529	IP65	

### Technical Data of the Proportional Solenoid

Nominal supply voltage	V	12 DC ±10 %	24 DC ±10 %
Limit current	A	1.9	1.1
Mean resistance value at 20 °C (68 °F)	Ω	4.7	13.9

### Technical Data of the Electronics

Nominal supply voltage U <sub>cc</sub>	V	12 DC	24 DC
Supply voltage range	V	11.2 ... 14.7 DC	20 ... 30 DC
Stabilized voltage for control	V	5 DC (R > 1 kΩ)	10 DC (R ≥ 1 kΩ)
Control signal	see table of switches configuration (page 6)		
Maximum output current	A	2.4 for R < 4Ω	1.5 for R < 10Ω
Ramp adjustment range	s	0.05 ... 3	
Dither frequency	Hz	90 / 60	
Dither amplitude	%	0 ... 30	

### Limit Power

Measured at v = 32 mm<sup>2</sup>/s (166 SUS)

Nominal flow 30 L/min (7.93 GPM)

Nominal flow 60 L/min (15.85 GPM)

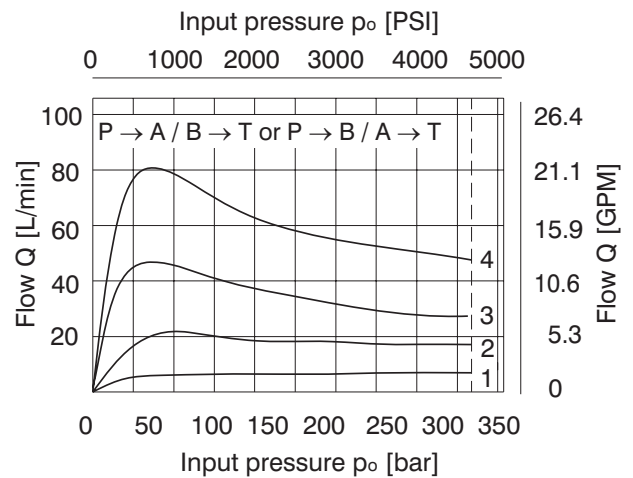
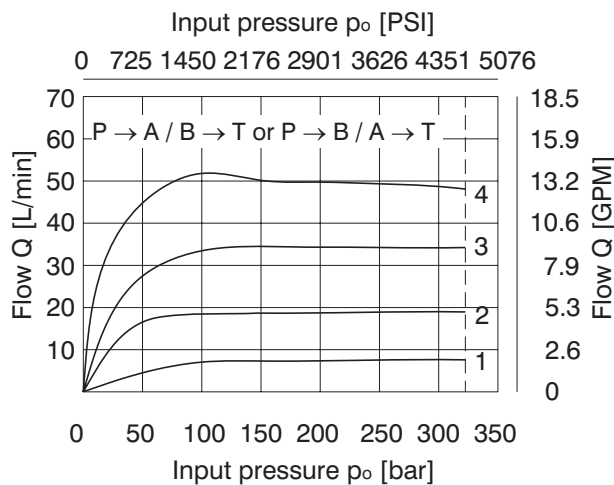

## Flow Characteristic with Integrated Electronics

Measured at  $\Delta p = 10 \text{ bar}$  (145 PSI),  $v = 32 \text{ mm}^2/\text{s}$  (156 SUS)

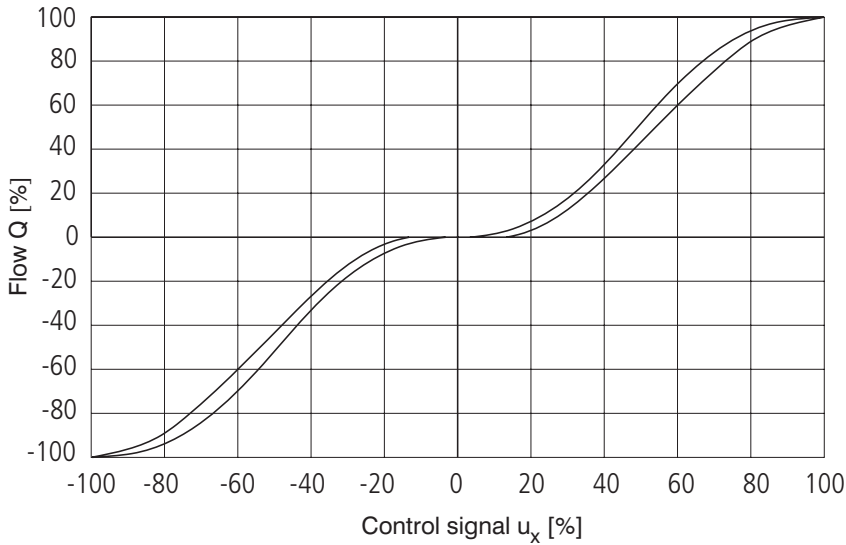

## Flow Characteristic without Integrated Electronics

Measured at  $\Delta p = 10 \text{ bar}$  (145 PSI),  $v = 32 \text{ mm}^2/\text{s}$  (156 SUS),

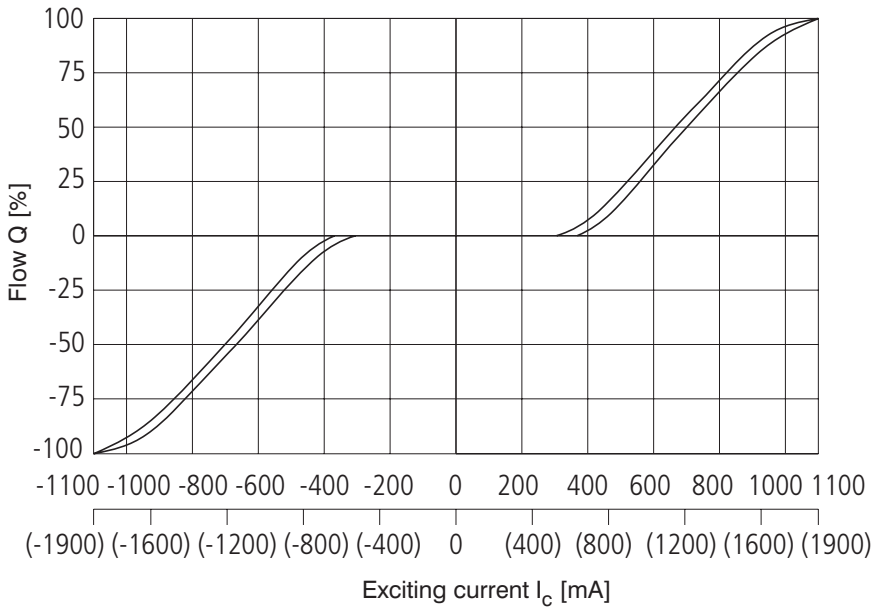

Values in parenthesis are valid for the supply voltage 12 V.

The coil current which initializes the flow through the proportional directional valve can differ due to the production tolerances about in a range of  $\pm 6\%$  of the limit current.

## Transient Characteristic

Measured at  $\Delta p = 10 \text{ bar}$  (145 PSI),  $v = 32 \text{ mm}^2/\text{s}$  (156 SUS);  $Q = 80\% Q_n$

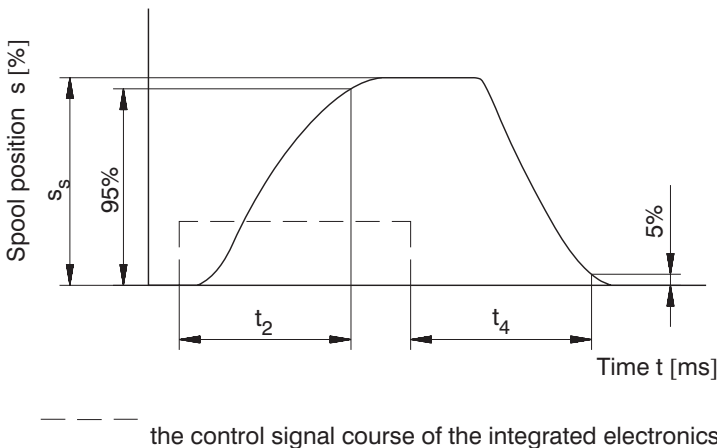

Steady spool position $s_s$ [%]	$t_2$ [ms]	$t_4$ [ms]
100	160	145
75	135	130
50	85	105
25	50	70

The values in table have only an informative character.

The times of the transient characteristics at pressure or flow control will be in a particular hydraulic circuit always longer.

# Frequency Reponse

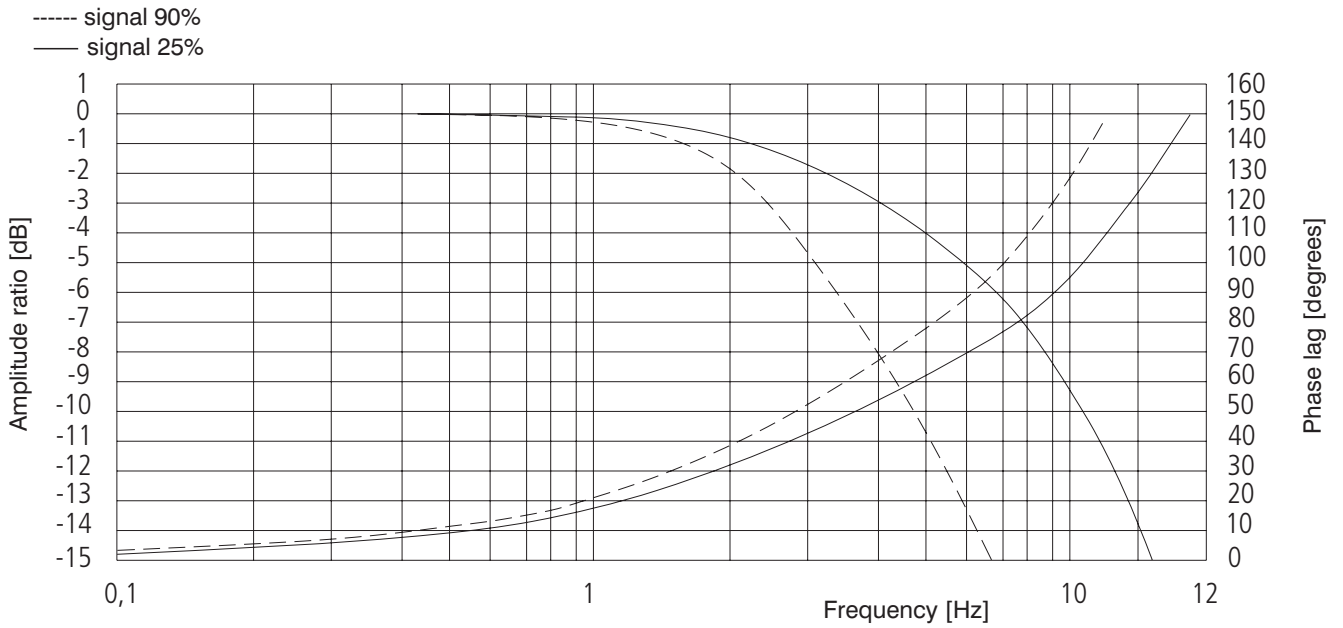

# Component Arrangement on the Electronic Card

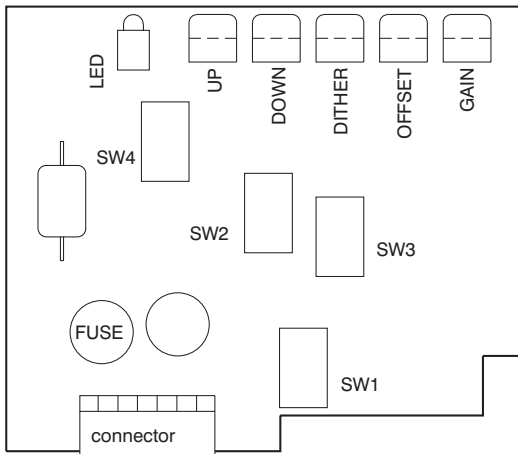

- SW1 - control signal choice
- SW2 - control signal choice
- SW3 - control signal choice
- SW4 - dither frequency

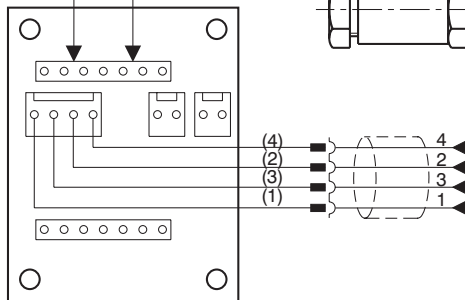

Description basic subplatte

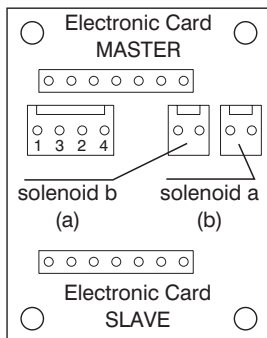
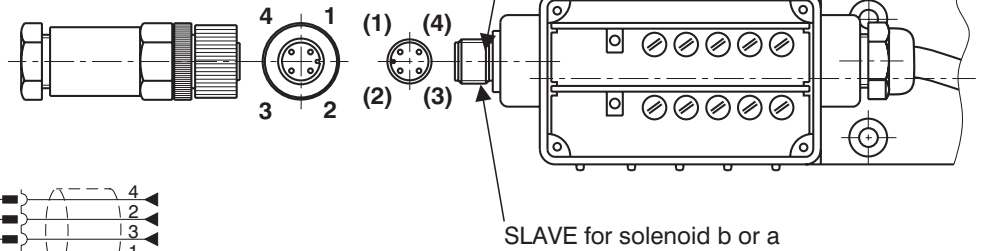

PIN	Description
1	+24 V ( $U_{CC}$ ) (+12 V)
2	control
3	0 V
4	+10 V (+5 V)

# Table of the Switch Configuration for the Control Signal Choices

		PRM6-102				PRM6-103	
		0 ... 5 V	0 ... 10 V (0 ... 5 V)*	0 ... 20 mA	4 ... 20 mA	$U_{cc}/2$ $\pm 10 V (\pm 5 V)^*$	$\pm 10 V$ $(\pm 5 V)^*$
MASTER M	SW1						
	SW2						
	SW3						
	SW4	90 Hz			60 Hz		
SLAVE S	SW1	X					
	SW2						
	SW3						
	SW4					90 Hz	

Designation of the basic manufacture setting.



The ramp functions are adjusted on their minimum values, the dither is set to the optimal value with respect to hysteresis. Offset and Gain are adjusted according to the characteristic on page 3 and 4. The manufacturer does not recommend these adjusted values to be changed.

\* Input signal level for the 12 V electronic unit.

## Block Diagram

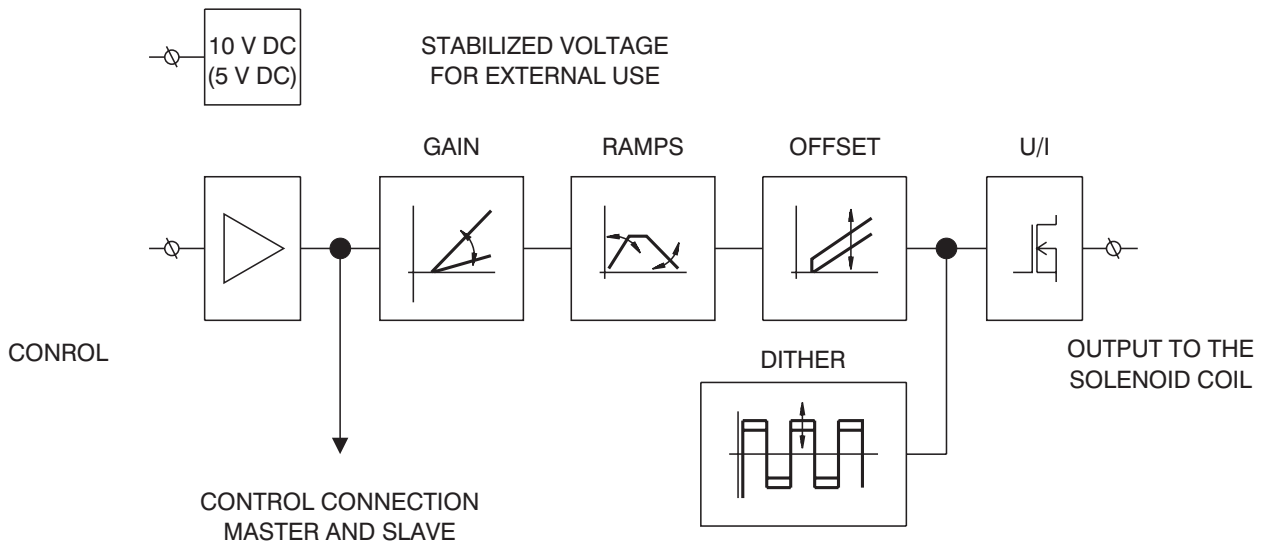

# Valve PRM6-102 (with One Solenoid)

## 1 Factory setting

### 1.1 Control with external voltage source 0 ... 10 V (0 ... 5 V) or with external potentiometer R > 1 kΩ

**Notice:**

The control signal must have the same ground potential as the supply source.

### Master card for solenoid a (b)

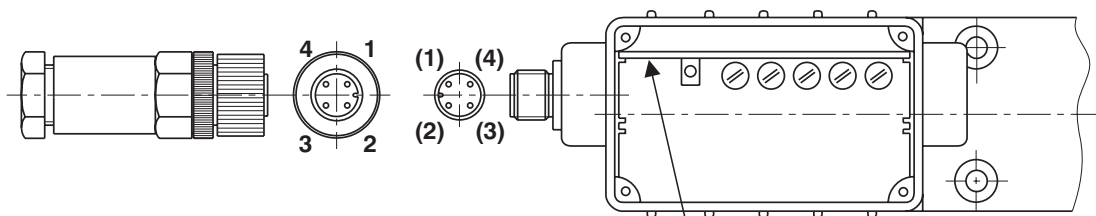
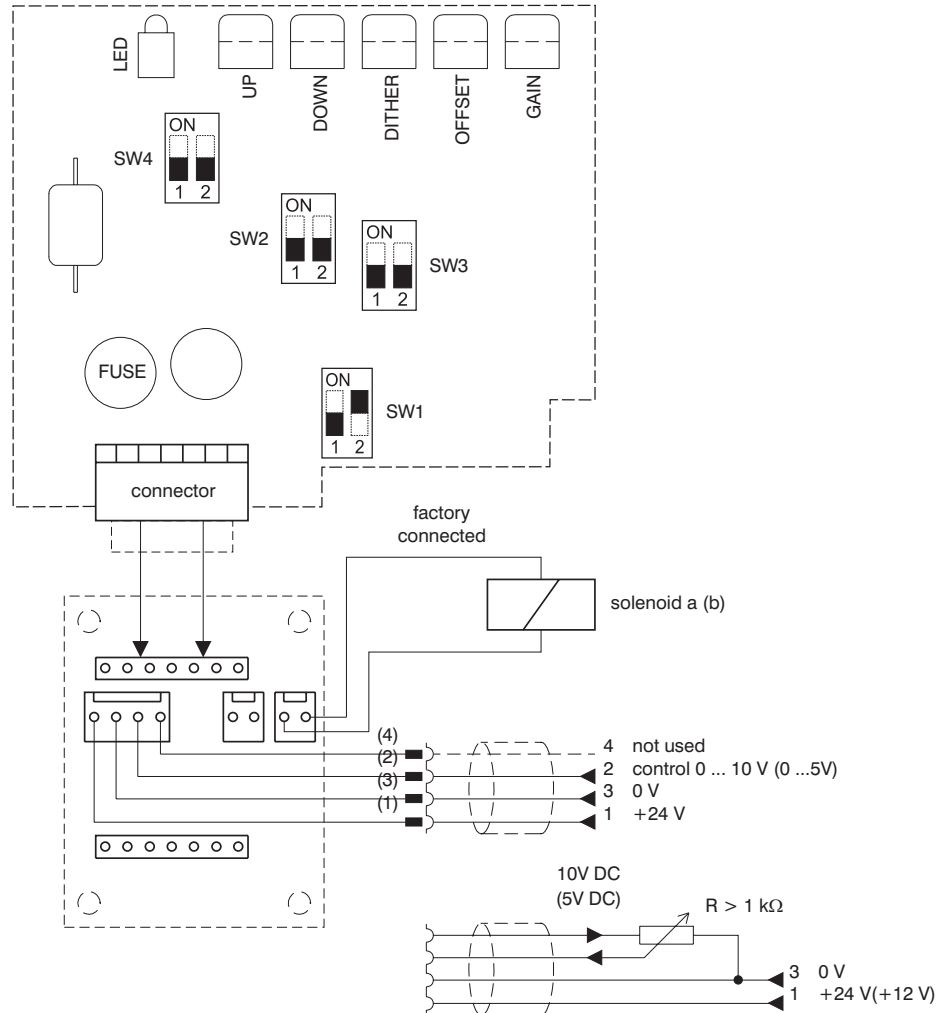

**Wire colours (connection connector - electronics):**

- (1) - brown
- (2) - white
- (3) - blue
- (4) - black

**Factory set values:**

**Control signal:** 0 - 10 V (0 - 5V)

**Dither:** frequency 90Hz  
amplitude - optimum

**Ramps:** 0.05 s

**Offset, Gain:** according to the characteristics on page 3, 4

## Valve PRM6-102 (with One Solenoid)

### 2 Other control possibilities

#### 2.1 Control with external source 0 ... 5 V

##### Notice:

The control signal must have the same ground potential as the supply source.

#### Master card for solenoid a (b)

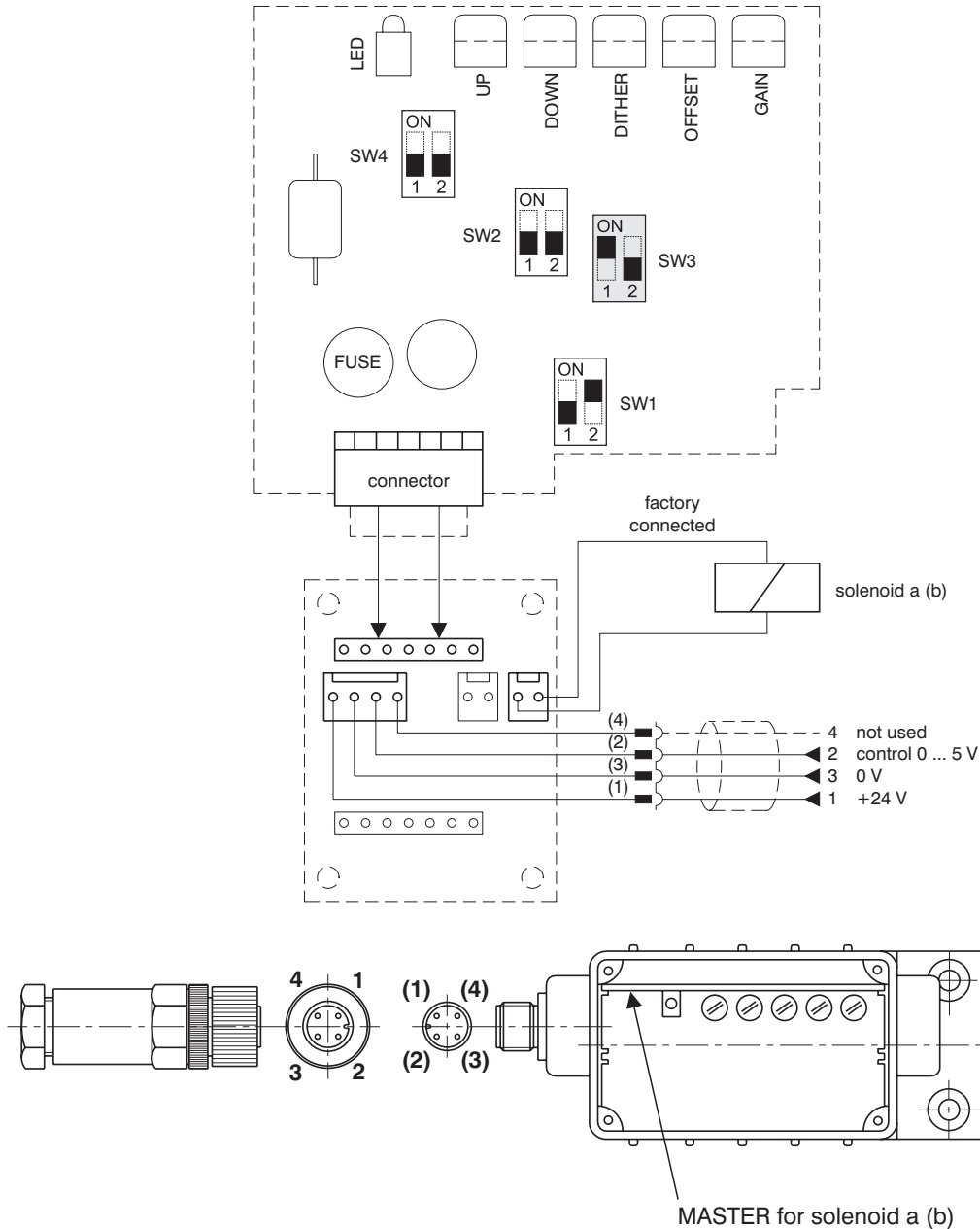

#### For the factory setting modification for this case of application, the following steps are required:

1. Unscrew the electronics cover
2. Carefully remove the Master card
3. Flip the switch SW3 in position shown in the picture
4. Put in the Master card and fix the electronics cover
5. Connect the voltage +24 V from an external supply source to terminals 1 and 3 of the connector
6. Connect the control voltage 0 ... 5 V from an external source to terminals 2 and 3 of the connector



## Valve PRM6-102 (with One Solenoid)

### 2.2 Control with external source 0 ... 20 mA

#### Notice:

The control signal must have the same ground potential as the supply source.

#### Master card for solenoid a (b)

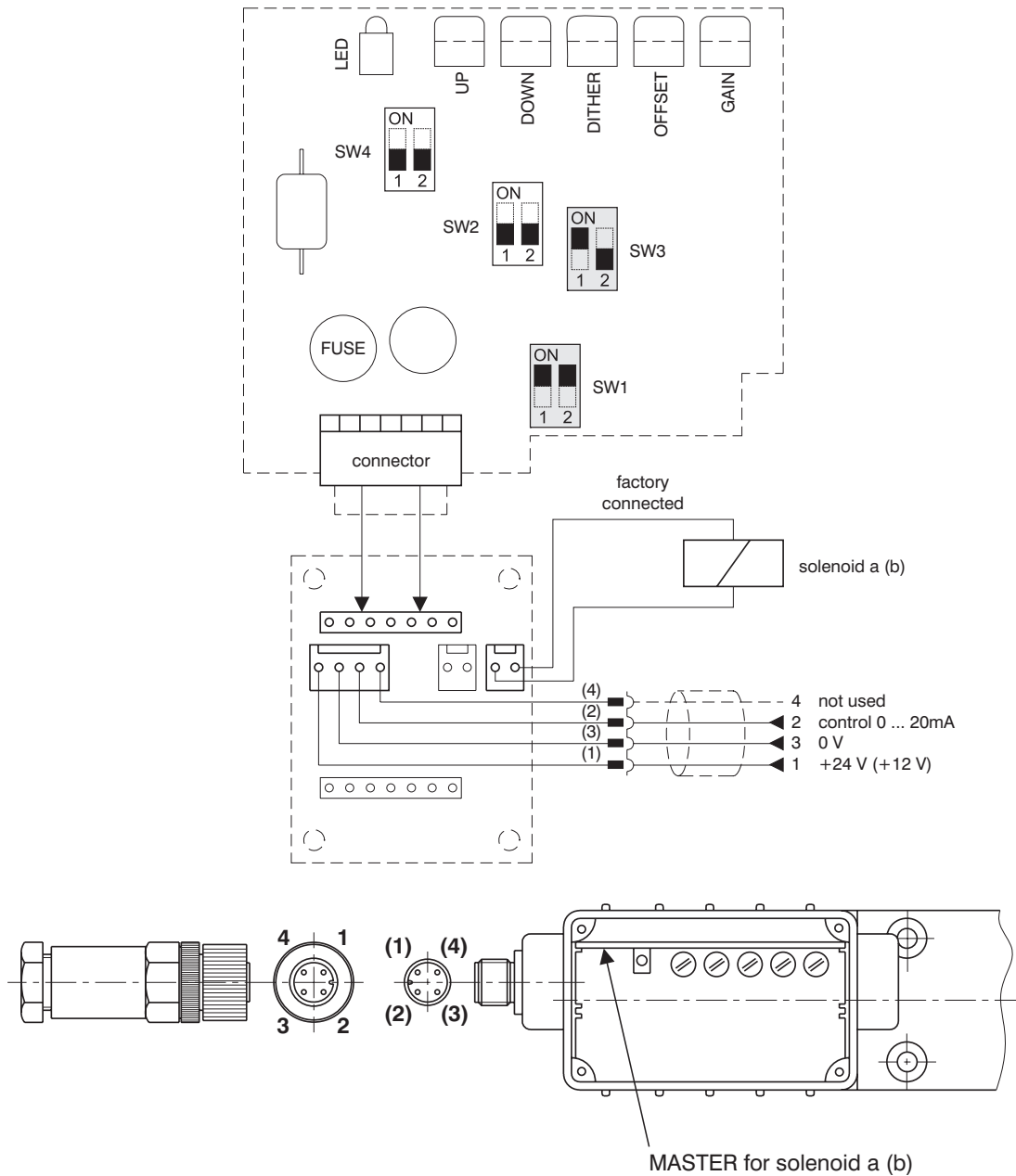

**For the factory setting modification for this case of application, the following steps are required:**

1. Unscrew the electronics cover
2. Carefully remove the Master card
3. Flip the switch SW1 and SW3 in position shown in the picture
4. Put in the Master card and fix the electronics cover
5. Connect the voltage +24 V (+12 V) from an external supply source to terminals 1 and 3 of the connector
6. Bring the control current 0 ... 20 mA from an external source to terminals 2 and 3 of the connector

## Valve PRM6-102 (with One Solenoid)

### 2.3 Control with external source 4 ... 20 mA

#### Notice:

The control signal must have the same ground potential as the supply source.

#### Master card for solenoid a (b)

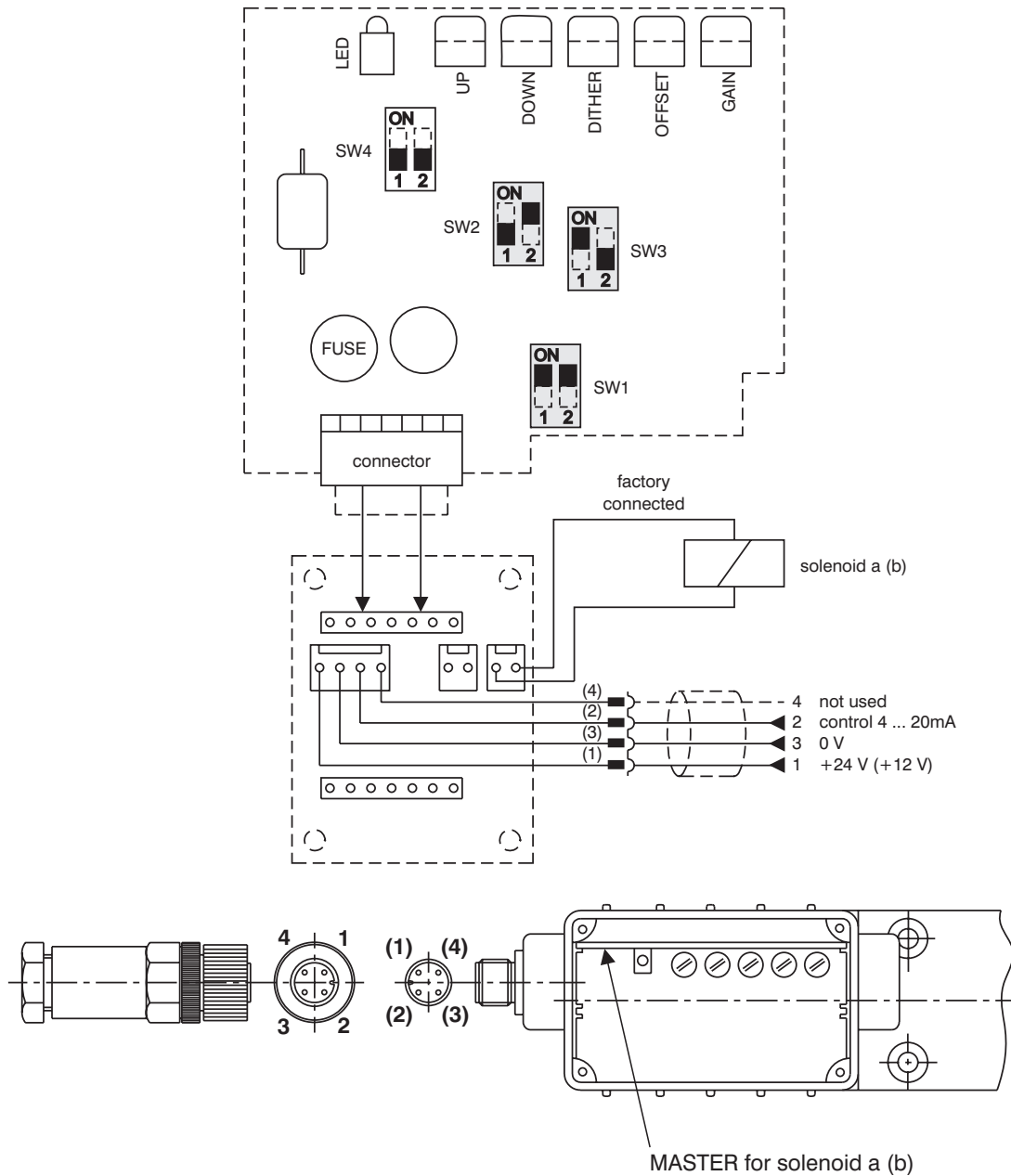

#### For the factory setting modification for this case of application, the following steps are required:

1. Unscrew the electronics cover
2. Carefully remove the Master card
3. Flip the switch SW1, SW2 and SW3 in position shown in the picture
4. Put in the Master card and fix the electronics cover
5. Connect the voltage +24 V (+12 V) from an external supply source to terminals 1 and 3 of the connector
6. Bring the control current 4 ... 20 mA from an external source to terminals 2 and 3 of the connector

# Valve PRM6-103 (with Two Solenoids)

## 3 Factory setting

### 3.1 Control with external source $0 \pm 10 \text{ V}$ ( $0 \pm 5 \text{ V}$ )

**Notice:**

The control signal must have the same ground potential as the supply source.

**Master card for solenoid a (b)**

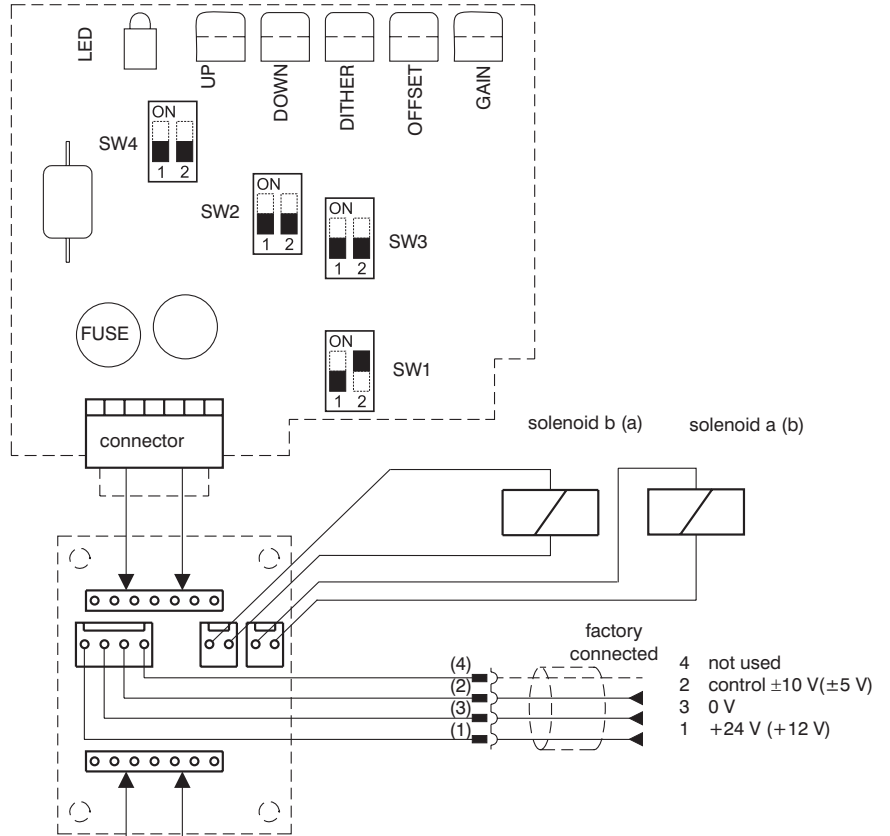

**Slave card for solenoid b (a)**

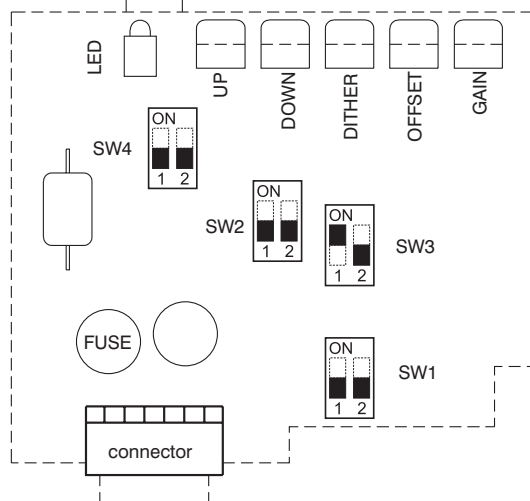

**Factory set values:**

**Control signal:**  $0 \pm 10 \text{ V}$  ( $0 \pm 5 \text{ V}$ )

**Dither:** frequency 90 Hz  
amplitude - optimum

**Ramps:** 0.05 s

**Offset, Gain:** according to the characteristics on page 3, 4

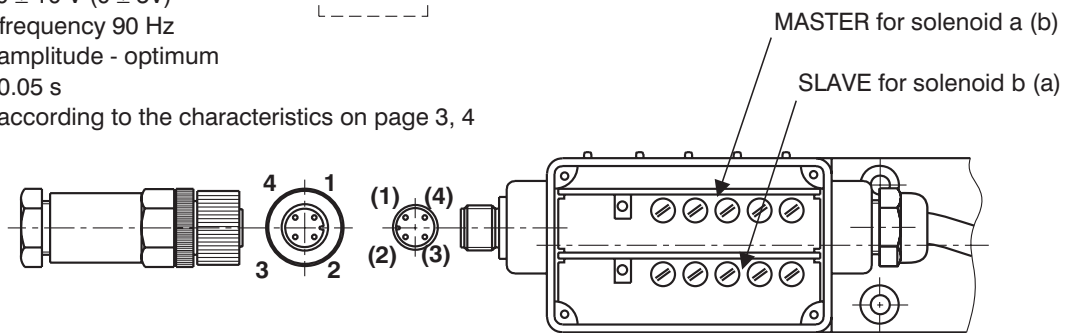

## Valve PRM6-103 (with Two Solenoids)

### 3.2 Other control possibilities

Control  $U_{cc}/2 \pm 10 V (U_{cc}/2 \pm 5V)$  external potentiometer  $R > 1 k\Omega$

#### Master card for solenoid a (b)

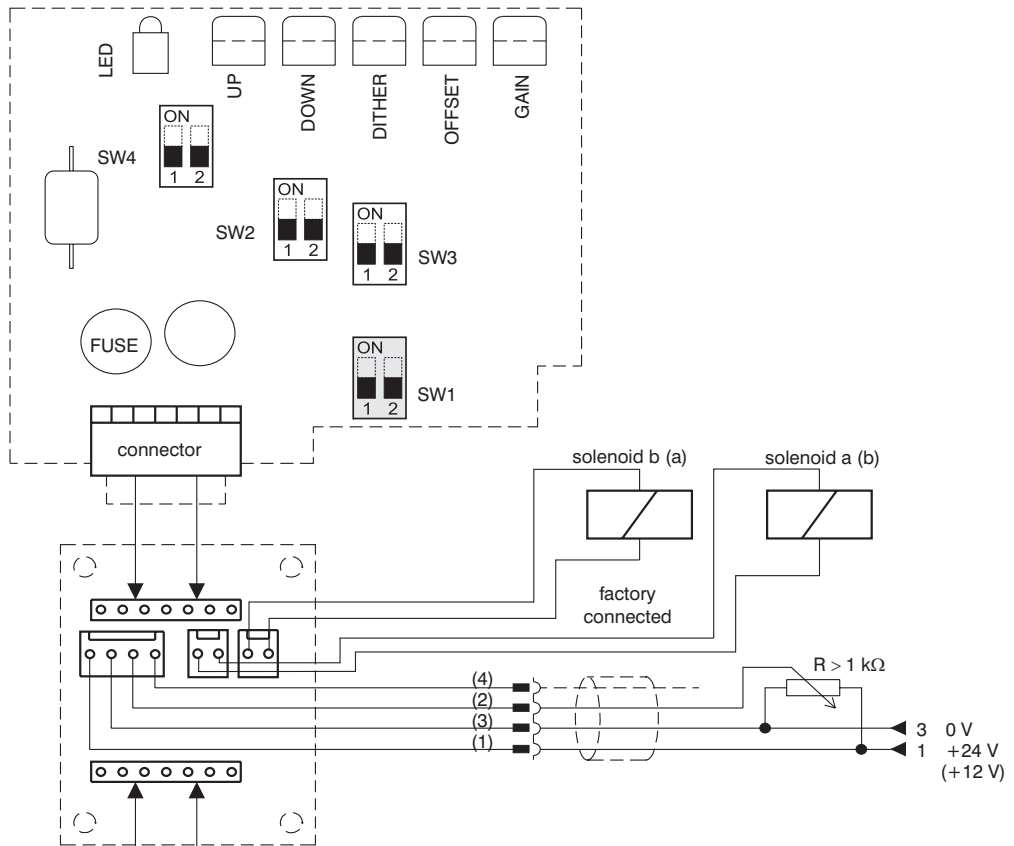

#### Slave card for solenoid b (a)

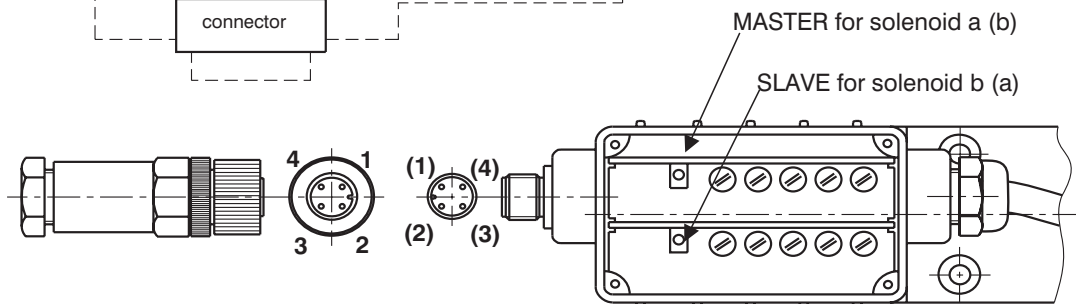
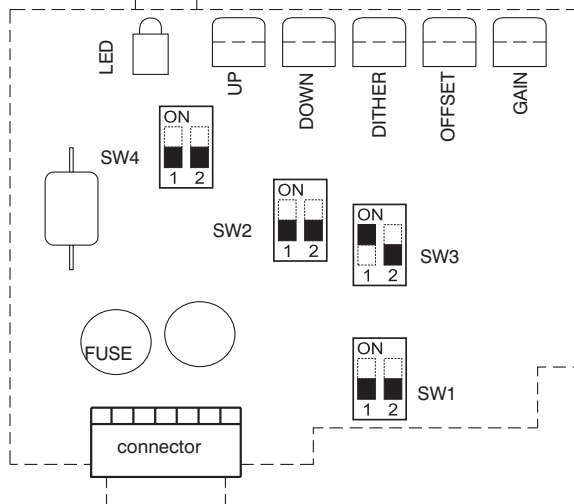

**For the factory setting modification for this case of application, the following steps are required:**

1. Unscrew the electronics cover
2. Carefully remove the Master card
3. Flip the switch SW1 in position shown in the picture
4. Put in the Master card and fix the electronics cover
5. Connect the voltage +24 V (+12 V) from an external supply source to terminals 1 and 3 of the connector

## Ramp Adjustment (Up, Down)

**Notice:** The factory setting of the ramp functions is to the minimum values.

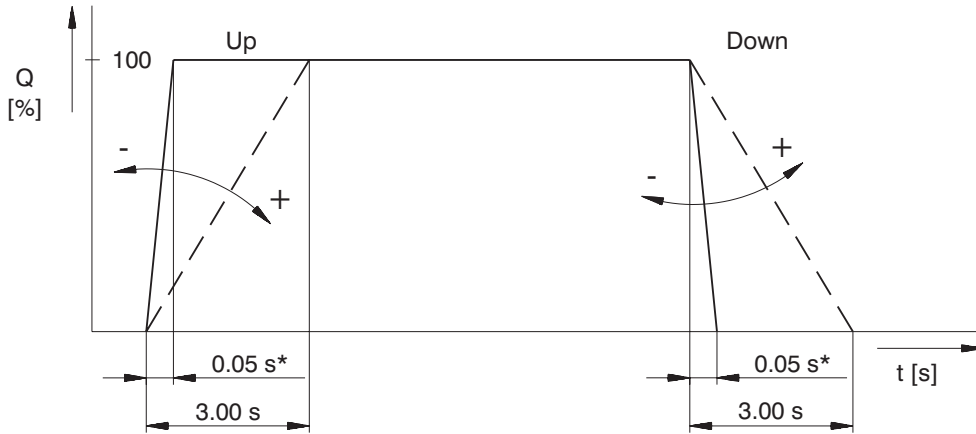

\*The value has only an informative character with respect to the particular type of the proportional directional valve (see page 4)

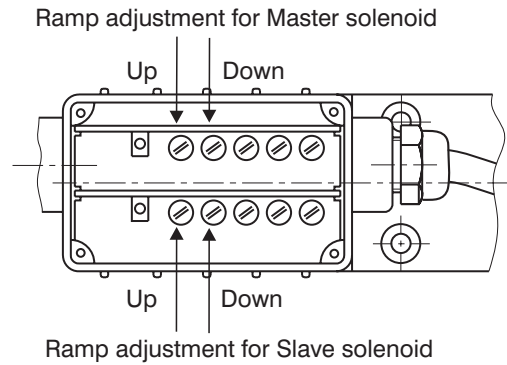
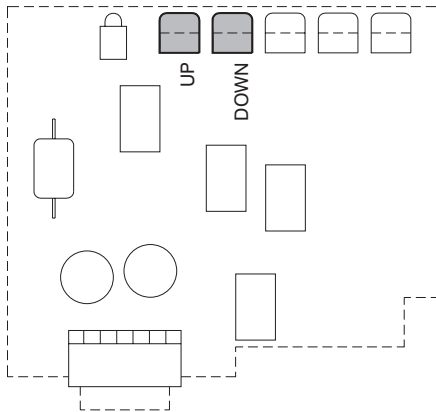
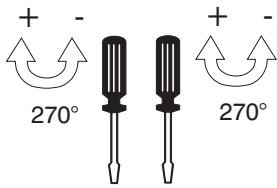

## Dither Adjustment

**Notice:** The dither is adjusted with regard to the minimum hysteresis.

**Amplitude** - potentiometer (dither) (0 - 30 %)

**Frequency** - switch SW4

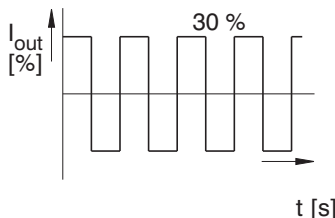
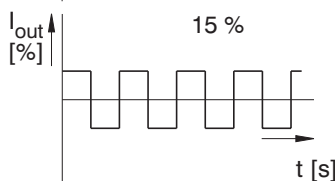
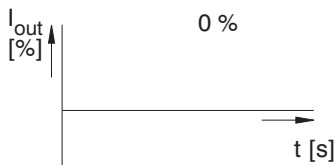

Amplitude adjustment for Master solenoid

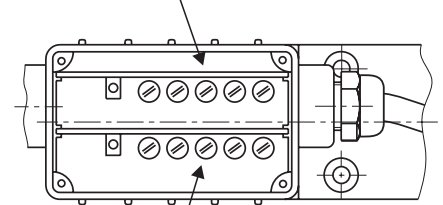

Amplitude adjustment for Slave solenoid

# Adjustment of Offset, Gain Parameters

**Notice:** The factory setting of the Offset and Gain parameters is specific for the solenoids used.  
The manufacturer does not recommend this setting to be changed.

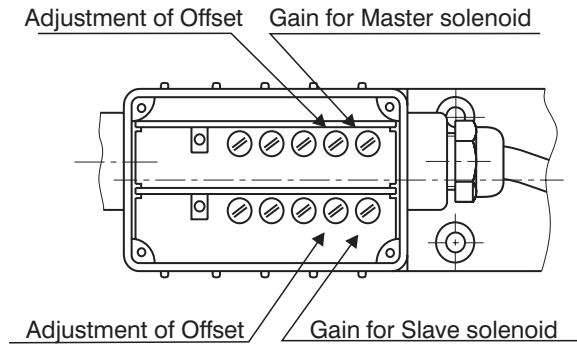
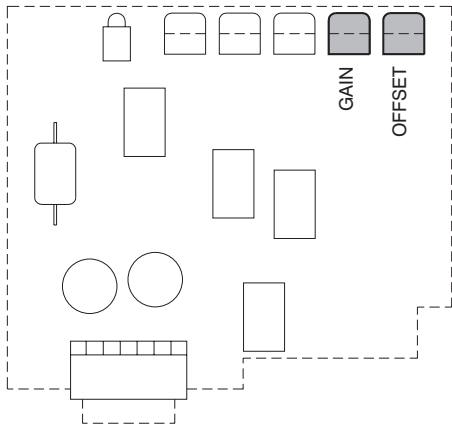
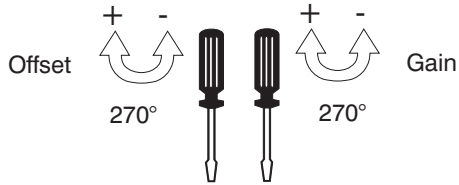
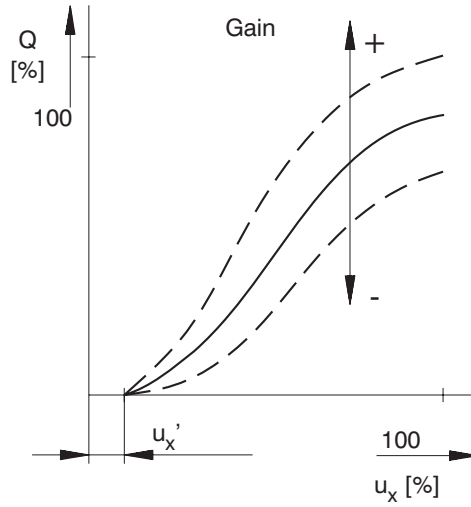
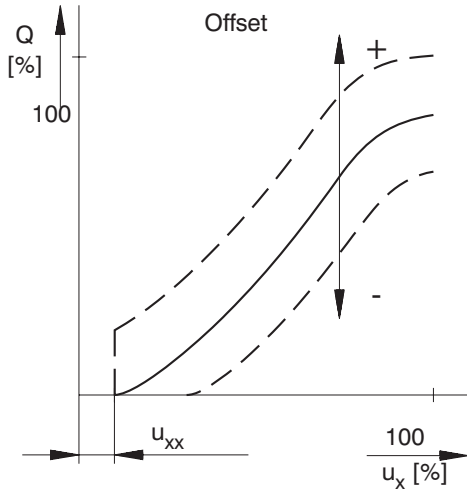

Nominal supply voltage of electronics [V]	Area insensible to control signal $u_{xx}$ [%]
12	1 ... 3
24	0.5 ... 2

# Valve Dimensions

Dimensions in millimetres ( in inches )

PRM2-102..../-...-

Functional symbols  
2Z51, 2Y51

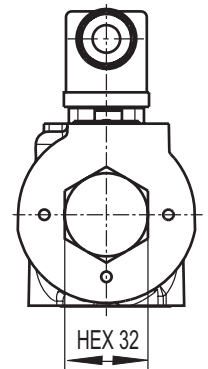
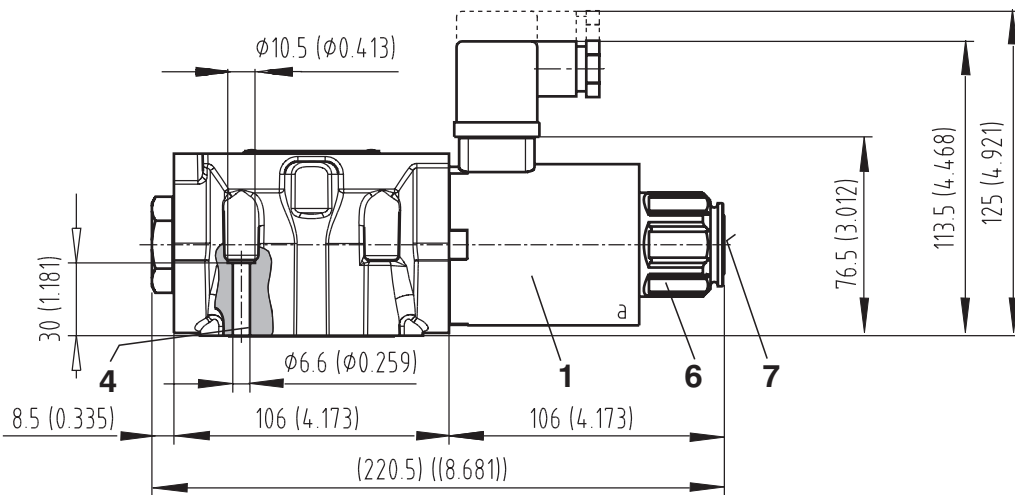
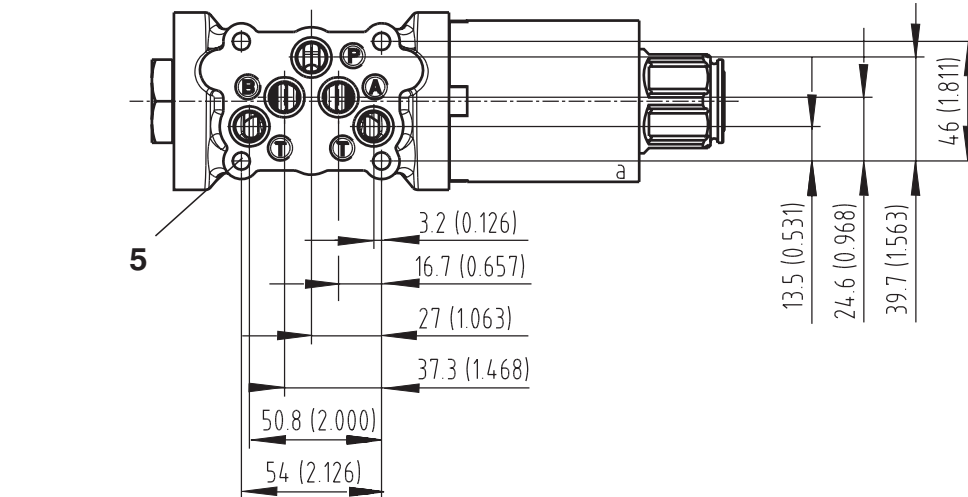

Functional symbols  
2Z11, 2Y11

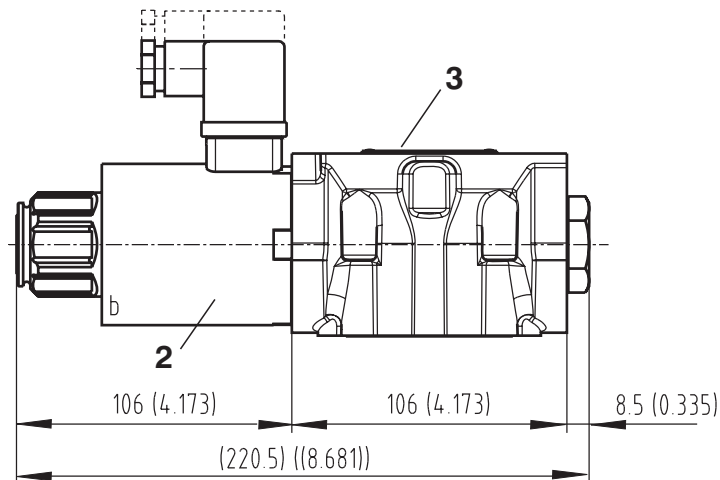

- 1 Solenoid a
- 2 Solenoid b
- 3 Name plate
- 4 Square ring 12.42 x 1.68 (5 pcs.)  
supplied in delivery packet
- 5 4 through mounting holes
- 6 Solenoid fixing nut [Nut torque 6 Nm (4.43 lbf.ft.)]
- 7 Manual override

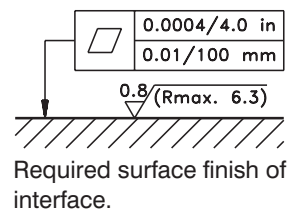

# Valve Dimensions

Dimensions in millimetres ( in inches )

PRM6-103..../-...-

Functional symbols  
3Z11, 3Z12, 3Y11, 3Y12

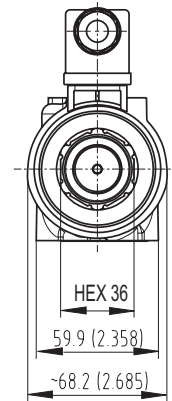
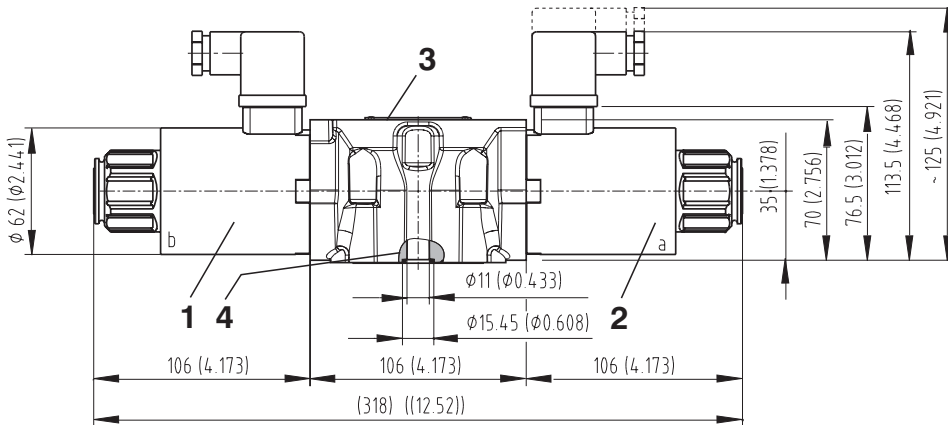
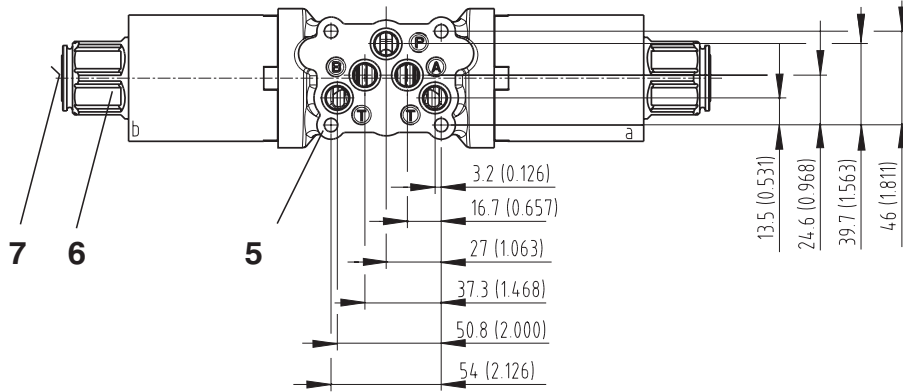

- 1 Solenoid a
- 2 Solenoid b
- 3 Name plate
- 4 Square ring 12.42 x 1.68 (5 pcs.)  
supplied in delivery packet
- 5 4 through mounting holes
- 6 Solenoid fixing nut [Nut torque 6 Nm (4.43 lbf.ft.)]
- 7 Manual override

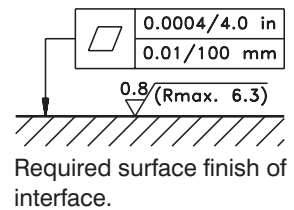



# Valve Dimensions

Dimensions in millimetres ( in inches )

## PRM6-102..../-...EK..

Functional symbols  
2Z51, 2Y51

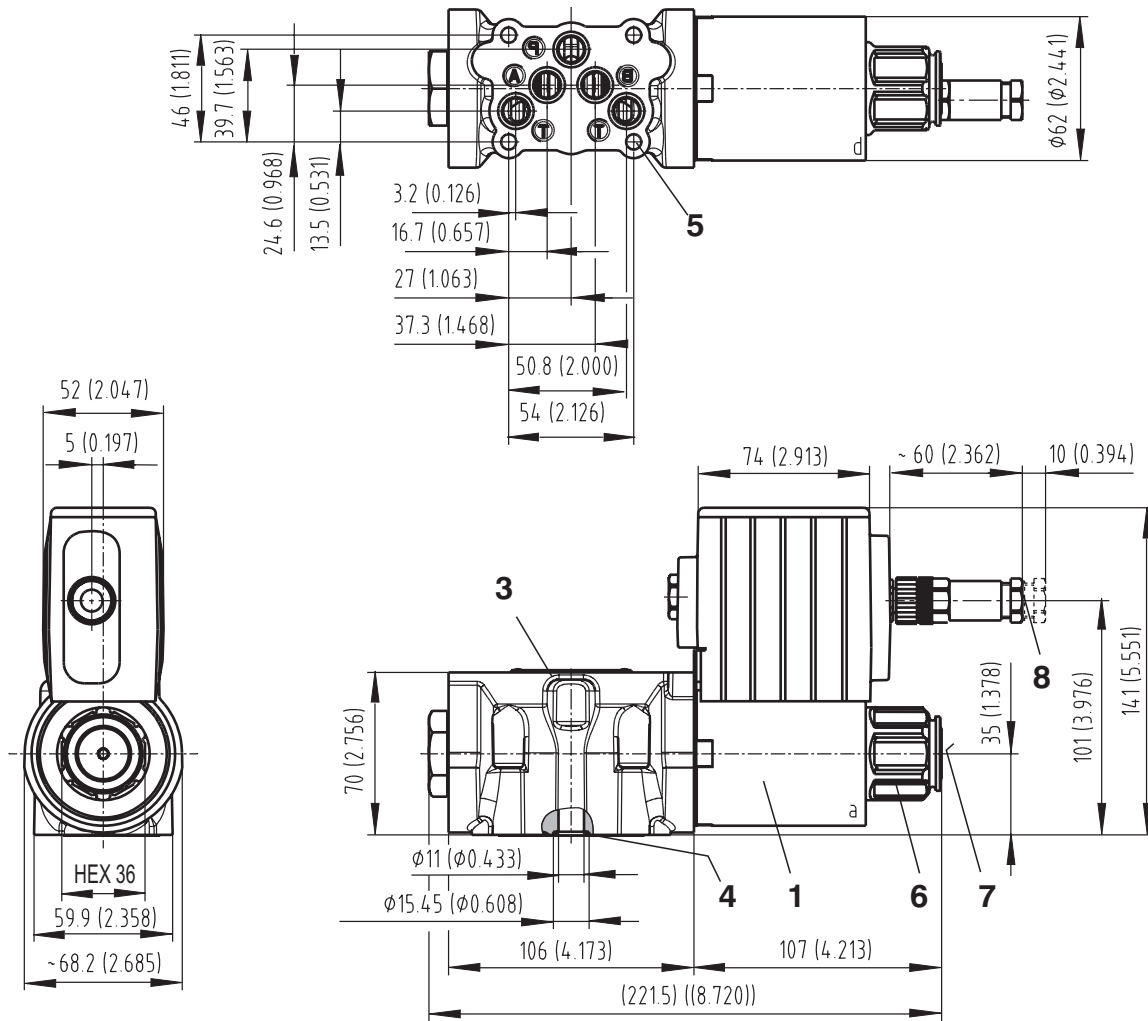

## PRM6-102...B/-...EK..

Functional symbols  
2Z11, 2Y11

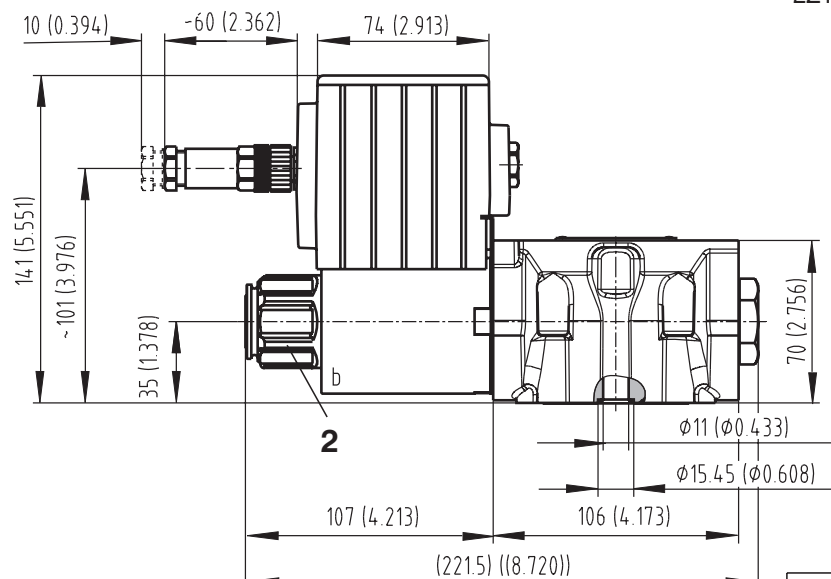

- 1 Solenoid a
- 2 Solenoid b
- 3 Name plate
- 4 Square ring 12.42 x 1.68 (5 pcs.)  
supplied in delivery packet
- 5 4 through mounting holes
- 6 Solenoid fixing nut [Nut torque 6 Nm (4.43 lbf.ft.)]
- 7 Manual override
- 8 4- pin connector M12 x 1 for external supply voltage

	0.0004/4.0 in
	0.01/100 mm

0.8/(Rmax. 6.3)

Required surface finish of interface.

# Valve Dimensions

Dimensions in millimetres ( in inches )

## PRM6-103..../-...EK..

**Functional symbols**  
3Z11, 3Z12, 3Y11, 3Y12

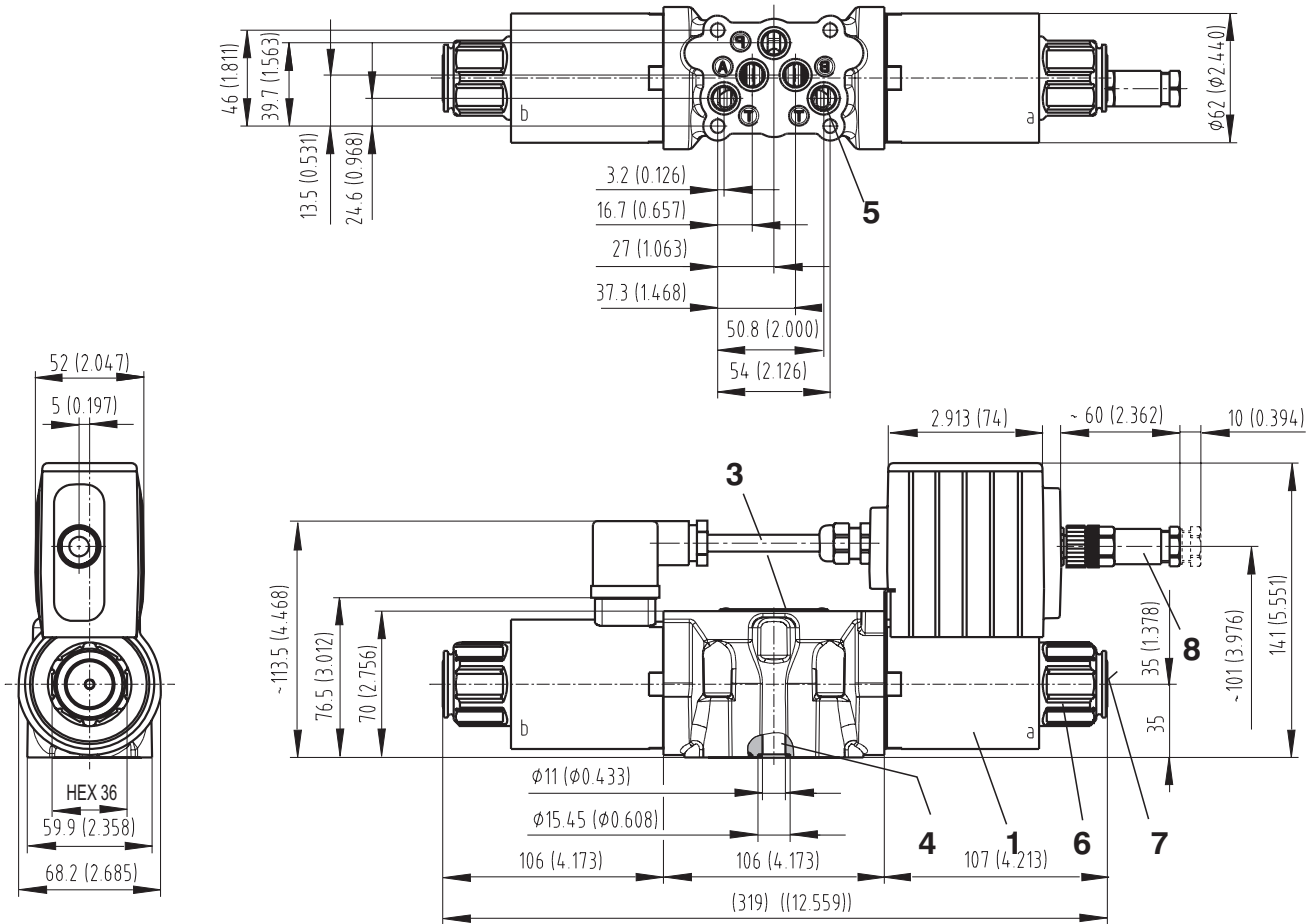

## PRM6-103...B/-...EK..

**Functional symbols**  
3Z11B, 3Z12B, 3Y11B, 3Y12B

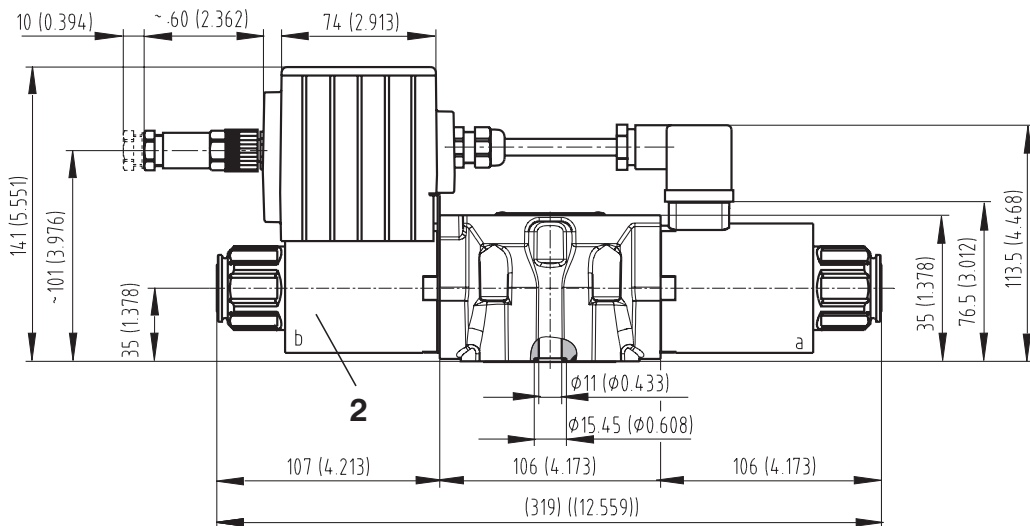

- 1 Solenoid a
- 2 Solenoid b
- 3 Name plate
- 4 Square ring 12.42 x 1.68 (5 pcs.)  
supplied in delivery packet
- 5 4 through mounting holes
- 6 Solenoid fixing nut [Nut torque 6 Nm (4.43 lbf.ft.)]
- 7 Manual override
- 8 4- pin connector M12 x 1 for external supply voltage

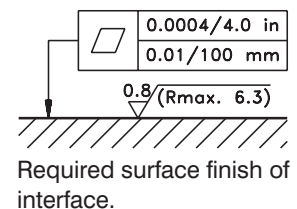

# Spare Parts

- 1 Solenoid coil
- 2 Nut + seal ring
- 3 Connector plug EN 175301-803
- 4 Seal kit
- 5 Bolt kit
- 6 Connector

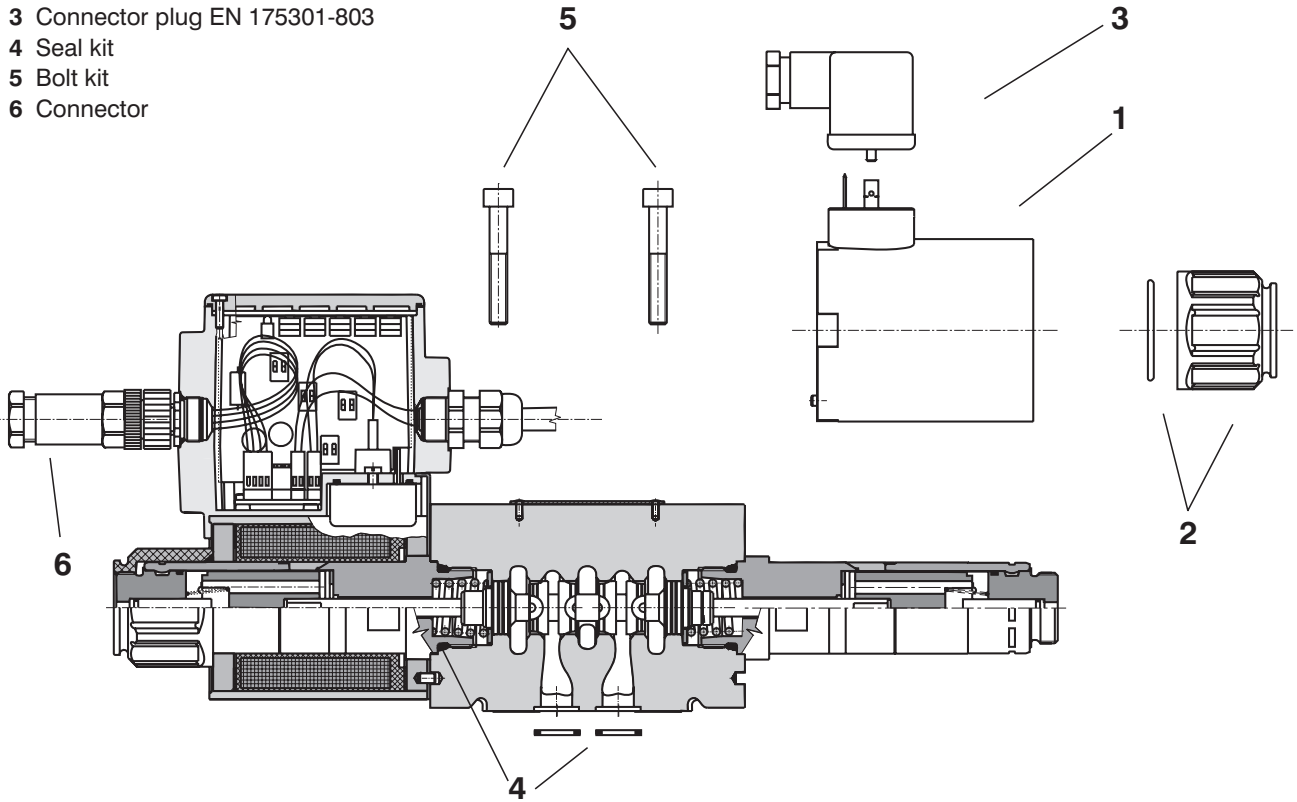

## 1. Solenoid coil

Nominal supply voltage [V]	Ordering number
12	936-4614
24	936-4629

## 2. Solenoid retaining nut + seal ring

Model of the nut	Seal ring	Ordering number
Standard nut	30 x 2	489-9900

## 3. Connector plug to EN 175301-803

Type designation	Type	Maximum input voltage	Connector plug A gray	Connector plug B black
			Ordering number	
K5	without rectifier - M16x1.5 bushing bore $\varnothing$ 4-6 mm ( $\varnothing$ 0.16-0.24 in)	230 V DC	936-9906	936-9905

## 4. Seal kit

Type	Dimensions, number		Ordering number
Standard - NBR 70	12.42 x 1.68 (5 pcs.)	23.81 x 2.62 (2 pcs.)	489-9902
Viton	12.42 x 1.68 (5 pcs.)	23.81 x 2.62 (2 pcs.)	489-9903

## 5. Bolt kit

Dimensions, number	Tightening torque	Ordering number
M6 x 40 DIN 912-10.9 (4 pcs.)	14 Nm (10.33 lbf.ft)	485-9964

## 6. Connector

Ordering number
M12 x 1 ( 4-pin connector)
358358904012

## Caution!

- The packing foil is recyclable. The protective plate can be returned to manufacturer.
- Mounting bolts M6 x 40 DIN 912-10.9 or studs must be ordered separately.  
Tightening torque of the bolts is 14 Nm (10.33 lbf.ft).
- The technical information regarding the product presented in this catalogue is for descriptive purposes only. It should not be construed in any case as a guaranteed representation of the product properties in the sense of law.

ARGO-HYTOS s.r.o. CZ - 543 15 Vrchlabí  
Tel.: +420-499-403111, Fax: +420-499-403421  
E-mail: sales.cz@argo-hytos.com  
www.argo-hytos.com