



Ventilating Filters



L1.0406 • L1.0506

L1.0706 • L1.0807

- Connection up to M60 x 2
- Nominal flow rate up to 850 l/min

Description

Application

Ventilation of tanks for hydraulic and lubrication systems, and gearboxes.

General

The oil levels in the tanks of hydraulic systems are subject to continuous variation due to temperature changes and the operation of cylinders and pressure vessels.

In order to prevent over pressure in the tanks, an exchange of air with the external atmosphere is necessary. By the use of a ventilating filter, the outside air that is drawn in is filtered and the ingress of dust is therefore prevented.

Special features

The ventilation openings are designed that dust on the surface of the tank is not drawn in, and that the ingress of spray and rainwater is largely prevented.

The use in marine applications presents no problem due to the use of synthetic materials and stainless steel.

Design

Flow direction bi-directional (air IN/OUT). The star-shaped pleating of the filter material results in:

- large filter surfaces
- low pressure drop
- high dirt-holding capacities
- long service life

Ordering options / versions

Integrated oil-level dipstick (for all types):

A dipstick can be integrated in the ventilating filter for checking the oil level. Therefore, a separate dipstick or an additional opening in the tank is not required.

Oil separator (L1.0406):

An effective protection against splashing oil in mobile operation.

Double check valves (L1.0506, L1.0807):

By the use of double check valves, the exchange of air between the tank and the environment can be considerably reduced, whereby the ingress of dust is minimized and the lifetime of the air filter element can be increased.

With the double check valve, an over-pressure can be created in the tank in order to improve the suction conditions for the pumps.

A further advantage is the reduction of spray water entry and the loss of oil through the ventilating filter.

Vandalism proof types:

Ventilating filters in patented vandalism proof version, please see catalogue sheet 50.20.

Filling and ventilating filters in standard or patented vandalism proof version, see catalogue sheet 50.30.

Maintenance

Ventilating filters should be changed at least every 1000 operating hours, or at minimum once a year.

Characteristics

Nominal flow rate

Up to 850 l/min (see Selection Chart, column 2)

The nominal flow rates indicated by ARGO-HYTOS are based on the following criteria:

- Ventilating filters without double check valve:
 $\Delta p < 0,03$ bar
- Ventilating filters with double check valve:
 $\Delta p < 0,1$ bar for air IN

Connection

Threaded ports according to ISO 228 or DIN 13. Sizes see Selection Chart, column 6 (other port threads on request)

Filter fineness

2 μ m

Tested in a single pass test with ISO MTD

Hydraulic fluids

Mineral oil and biodegradable fluids
(HEES u. HETG, see info sheet 00.20)

Temperature range hydraulic fluid

- 30 °C ... + 100 °C

Temperature range environment

- 30 °C ... + 100 °C

Materials

Cap:	Polyamide, GF reinforced (L1.0506 Polyester, GK reinforced)
Base:	Polyamide, GF reinforced (L1.0506 Polyester, GK filled)
Dipstick:	Stainless steel (1.4301)
Gaskets:	NBR (Viton on request)
Filter media:	Composite, multi-layer

Mounting position

No limitation, position on the tank see section Layout

Diagrams

Δp -curves for complete filters in Selection Chart, column 2

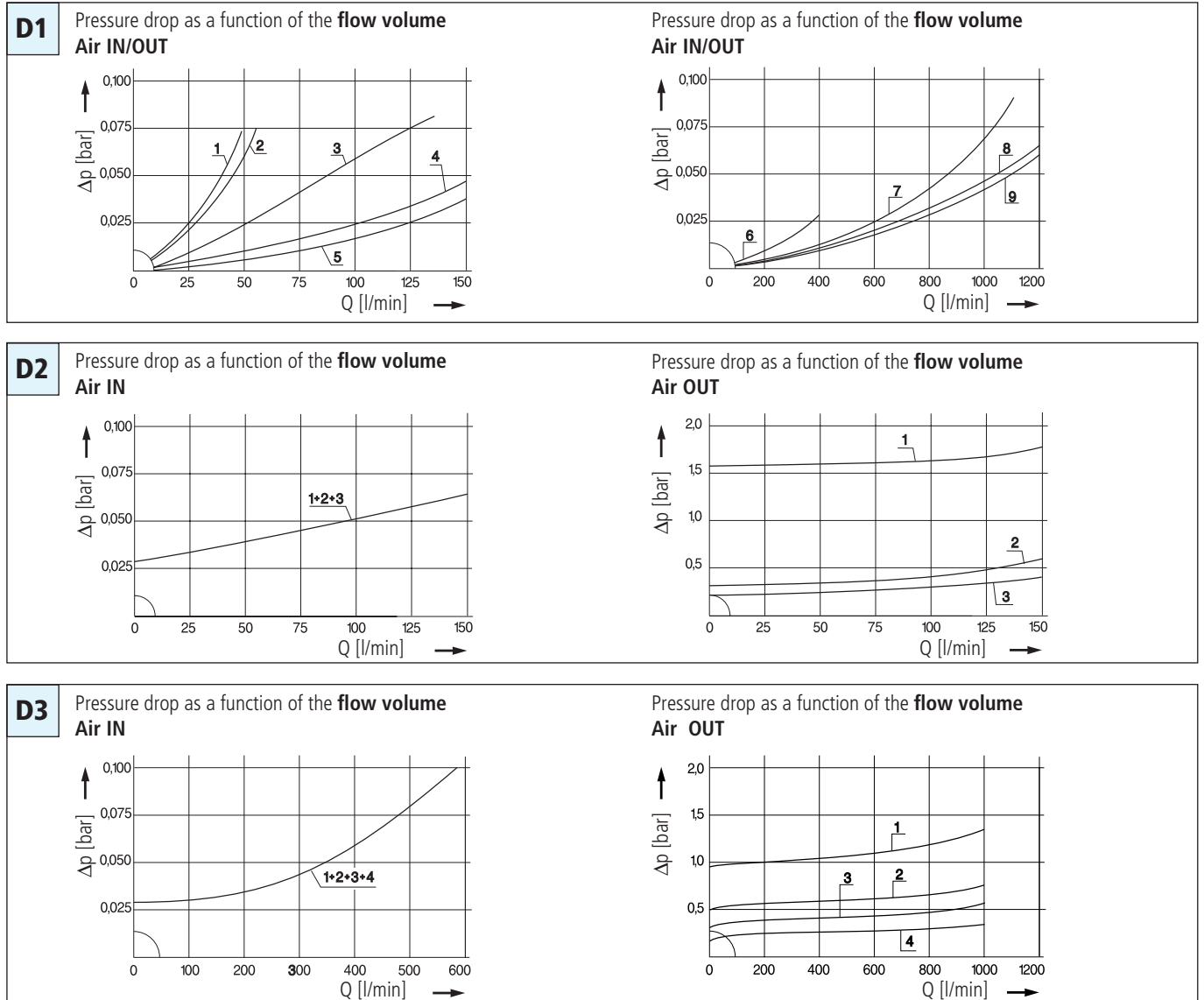

Filter fineness curves in Selection Chart, column 4

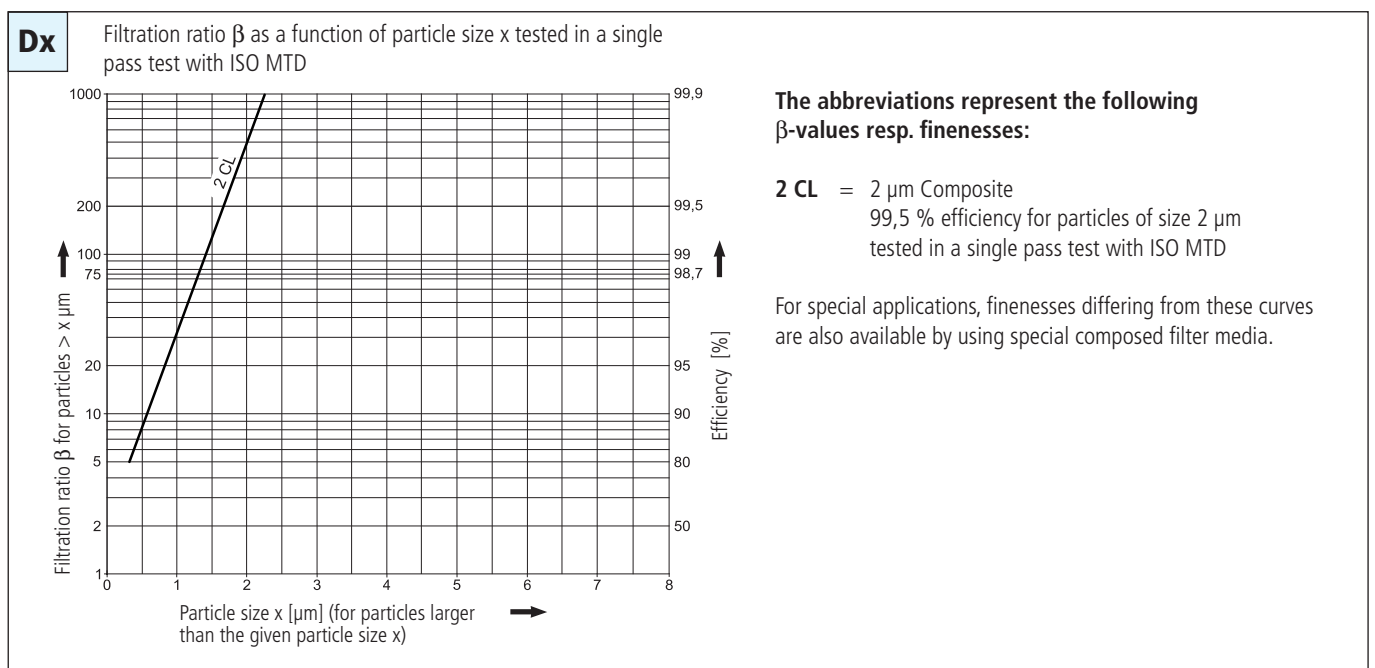

Selection Chart

Part No.	Nominal flow rate	Pressure drop see diagram D curve no.	Filter fineness see Diagr. Dx	Filter surface	Connection A	Cracking pressure air IN	Cracking pressure air OUT	Dipstick measurement L1	Dipstick measurement L2	Dipstick measurement L3	Symbol	Weight	Remarks
1	l/min	3	4	cm ²	6	bar	8	9	10	11	12	13	14
L1.0406-12	120	D1/4	2 CL	46	M18 x 1,5	-	-	-	-	-	1	25	-
L1.0406-21	25	D1/1	2 CL	46	M18 x 1,5	-	-	-	-	-	1	25	with labyrinth oil separator
L1.0406-73	25	D1/1	2 CL	46	M18 x 1,5	-	-	75	70	55	1	30	with labyrinth oil separator
L1.0406-76	25	D1/1	2 CL	46	M18 x 1,5	-	-	80	75	60	1	30	with labyrinth oil separator
L1.0406-45	25	D1/1	2 CL	46	M18 x 1,5	-	-	95	90	45	1	35	with labyrinth oil separator
L1.0406-69	25	D1/1	2 CL	46	M18 x 1,5	-	-	100	95	80	1	35	with labyrinth oil separator
L1.0406-56	25	D1/1	2 CL	46	M18 x 1,5	-	-	130	125	100	1	35	with labyrinth oil separator
L1.0406-03	135	D1/5	2 CL	46	M22 x 1,5	-	-	-	-	-	1	25	-
L1.0406-87	30	D1/2	2 CL	46	M22 x 1,5	-	-	-	-	-	1	25	with labyrinth oil separator
L1.0406-60	30	D1/2	2 CL	46	M22 x 1,5	-	-	85	80	55	1	30	with labyrinth oil separator
L1.0406-79	135	D1/2	2 CL	46	M22 x 1,5	-	-	120	115	90	1	35	-
L1.0406-51	30	D1/2	2 CL	46	M22 x 1,5	-	-	130	125	-	1	35	with labyrinth oil separator
L1.0406-59	30	D1/2	2 CL	46	M22 x 1,5	-	-	130	125	100	1	35	with labyrinth oil separator
L1.0406-98	30	D1/2	2 CL	46	M22 x 1,5	-	-	180	175	150	1	40	with labyrinth oil separator
L1.0406-33	30	D1/2	2 CL	46	M22 x 1,5	-	-	250	235	215	1	40	with labyrinth oil separator
L1.0406-101	16	D1/3	2 CL	5,5	M22 x 1,5	-	-	-	-	-	1	25	-
L1.0506-73	150 *	D2/3	2 CL	48	M22 x 1,5	-0,03	0,20	-	-	-	2	55	-
L1.0506-91	150 *	D2/2	2 CL	48	M22 x 1,5	-0,03	0,35	-	-	-	2	55	-
L1.0506-43	150 *	D2/1	2 CL	48	M22 x 1,5	-0,03	1,60	-	-	-	2	55	-
L1.0706-03	250	D1/6	2 CL	46	M30 x 1,5	-	-	-	-	-	1	50	-
L1.0706-02	250	D1/6	2 CL	46	M42 x 2,0	-	-	-	-	-	1	50	-
L1.0807-11	800	D1/8	2 CL	320	M30 x 1,5	-	-	-	-	-	1	140	with flat gasket
L1.0807-61	550 *	D3/3	2 CL	320	M30 x 1,5	-0,03	0,35	-	-	-	2	160	-
L1.0807-21	650	D1/7	2 CL	320	G¾	-	-	-	-	-	1	140	-
L1.0807-81	550 *	D3/4	2 CL	320	G¾	-0,03	0,20	-	-	-	2	160	with flat gasket
L1.0807-71	550 *	D3/3	2 CL	320	G¾	-0,03	0,35	-	-	-	2	160	-
L1.0807-93	550 *	D3/2	2 CL	320	G¾	-0,03	0,50	-	-	-	2	160	-
L1.0807-63	550 *	D3/1	2 CL	320	G¾	-0,03	1,00	-	-	-	2	160	-
L1.0807-31	850	D1/9	2 CL	320	M42 x 2,0	-	-	-	-	-	1	140	-
L1.0807-91	550 *	D3/4	2 CL	320	M42 x 2,0	-0,03	0,20	-	-	-	2	160	-
L1.0807-51	550 *	D3/3	2 CL	320	M42 x 2,0	-0,03	0,35	-	-	-	2	160	-
L1.0807-14	850	D1/9	2 CL	320	M60 x 2,0	-	-	-	-	-	1	140	-

Remarks:

- The ventilating filters listed in this chart are standard filters. If modifications are required, e.g., with integrated dipstick, we kindly ask for your request.
- Ventilating filters in Vandalism Proof design see catalogue sheet 50.20.

* Δp < 0,1 bar for air IN

Dimensions

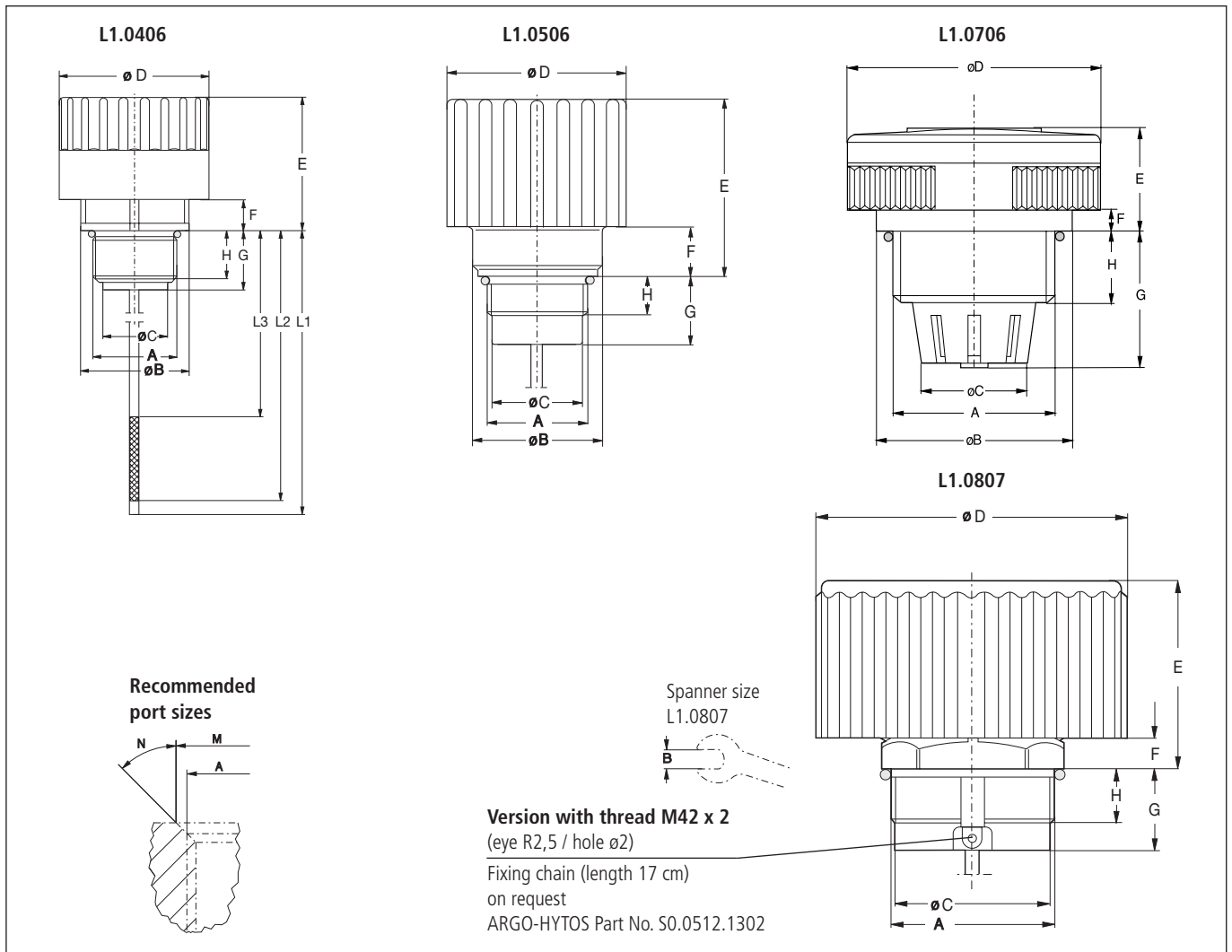

Measurements

Type	A*	B	C	D	E	F	G	H	M	N
L1.0406	M18 x 1,5, M22 x 1,5	31,5	16	37	33,5	7,5	16,5	13,5	as A	45°
L1.0506	M22 x 1,5	29	19,5	46	46	13	17,5	10,5	as A	45°
L1.0706	M30 x 1,5	51	20,5	66	26,5	6	35	18	as A	45°
	M42 x 2	51	28	66	26,5	6	35	18	as A	45°
L1.0807	M30 x 1,5	SW 47	27	80	50	7,5	17,5	13,5	as A	45°
	M42 x 2	SW 47	40	80	50	8	21	14	48	45°
	M60 x 2	SW 47	56,4	80	52	11	18	15	as A	45°
	G¾	SW 33	24	80	50	7,5	17,5	13,5	as A	45°

* The thread dimensions do not exactly conform to the DIN ISO standard thread (functioning with the DIN ISO standard thread is guaranteed)

Symbols

1

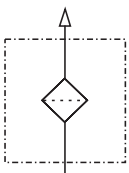

2

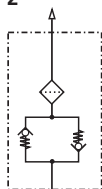

Layout

Sizes

The determining factor for selecting the size is the maximum over / under pressure allowed in the container.

For versions without double check valves, the initial pressure drop with a clean air filter should not exceed 0,03 bar.

For versions with double check valves, the initial pressure drop for air IN with a clean air filter should not exceed 0,1 bar.

Filter fineness

In the ideal case, the fineness of the ventilating filter matches the fineness of the system filter (see also CETOP RP 98 H).

By the use of filter fineness 2 CL the ingress of dust into the tank is effectively reduced.

Mounting

The ventilating filter should be mounted in a low-dust area of the machine and not in depressions in which water can collect.

For mobile use, the ventilating filter is to be mounted on the tank such that neither splashing oil from the inside nor spray water from the outside can reach the area of the ventilation opening.

Double check valves

By the use of double check valves, the exchange of air between the tank and the environment can be considerably reduced, whereby the ingress of dust is minimized and the lifetime of the air filter element is increased.

With the double check valve, a predefined level of pressure can be created in the tank in order to improve the suction conditions for the pumps.

The valve opening pressure required for the ventilating filter can be approximately determined with the ideal gas equation depending on the following system characteristics:

- differential volume,
- volume of oil in the system,
- volume of air in the tank and the
- operating temperatures.

Quality Assurance

Quality management according to DIN EN ISO 9001

To ensure constant quality in production and operation, ARGO-HYTOS filter elements undergo strict controls and tests according to the following DIN and ISO standards:

DIN ISO 2941	Verification of collapse/burst resistance
DIN ISO 2943	Verification of material compatibility with fluids
DIN ISO 3724	Verification of flow fatigue characteristics

ISO 2942 ISO 3968 ISO 16889

Verification of fabrication integrity (Bubble Point Test)
Evaluation of pressure drop versus flow characteristics
Multi-Pass-Test (evaluation of filter fineness and dirt-holding capacity)

Various quality controls during the production process guarantee the leakfree function and solidity of our filters.

Our engineers will be glad to advice you in questions concerning filter application, selection as well as the cleanliness class of the filtered medium attainable under practical operating conditions.

Illustrations may sometimes differ from the original. ARGO-HYTOS is not responsible for any unintentional mistake in this specification sheet.



We produce fluid power solutions

ARGO-HYTOS GMBH · Industriestraße 9 · D-76703 Kraichtal

Tel: +49 7250 76-0 · Fax: +49 7250 76-199 · info.de@argo-hytos.com · www.argo-hytos.com